



Uniden[®]

UM355 VHF Marine Radio

For more exciting new products please visit our website:
Australia: www.uniden.com.au

OWNER'S MANUAL

Making a distress call

Making a DISTRESS Call

Speak slowly - clearly - calmly.

For future reference, write your boat's name & call sign here:

1. Make sure your radio is on.
2. On the radio, press the 16/67-Tri button to switch to Channel 16 (156.8 MHz). (If the corner of the display does not show 16, press the 16/67-Tri button again until it does.)
3. Press the push to talk button and say: "MAYDAY -- MAYDAY -- MAYDAY."
4. Say "THIS IS {name of your boat (three times) and call sign/boat registration number (once)}."
5. Say "MAYDAY {name or call sign of your boat}."
6. Tell where you are: (what navigational aids or landmarks are near, or read the latitude and longitude from your GPS).
7. State the nature of your distress, (e.g. are you sinking, medical emergency, man overboard, on fire, adrift, etc.)
8. State the type of assistance you need (medical, towing, pumps, etc.).
9. Give number of persons aboard and conditions of any injured persons.
10. Estimate present seaworthiness of your ship (e.g. how immediate is the danger due to flooding or fire or proximity to shore).
11. Briefly describe your ship, giving the ship name (e.g. "Blue Duck is 32 foot cabin cruiser, white hull, blue deck house").
12. Say: "I WILL BE LISTENING ON CHANNEL 16."
13. End message by saying "THIS IS {name or call sign of your boat}, OVER."
14. Release the push to talk button and listen.

If you do not get an answer after 30 seconds, repeat your call, beginning at step 3, above.

Table of Contents

Making a DISTRESS Call.....	2
Table of Contents	3 (this page)
Introduction.....	5
Features.....	5
Manual overview.....	5
Conventions.....	5
Getting Started.....	6
What's included.....	6
Parts of the radio.....	7
Turning on the radio.....	10
Setting the UIC channel mode (USA/CAN/INT).....	10
How It Works.....	10
Normal mode operation.....	11
Using the radio in normal mode.....	12
Normal mode with Triple and Dual Watch.....	12
Scan mode.....	13
Using the radio in scan mode.....	13
Scan mode with Triple and Dual Watch.....	14
Weather mode.....	14
Using Your Radio.....	15
Setting the volume.....	15
Setting the squelch level.....	15
Changing the channel.....	15
Making a transmission.....	16
Boosting the transmission power.....	16
Instant Channel.....	16
Siren Out.....	17
Changing display and sound options.....	17
Dimmer.....	17
Turning the key beep on and off.....	17
Installing the Hardware.....	18
Mounting the radio.....	18
Installing flush mount bracket.....	20
Connecting the radio.....	21
Connecting accessories.....	23
Connecting to an external speaker.....	23
Maintenance and Troubleshooting.....	24
Common questions.....	24
Engine Noise Suppression.....	25
Specifications.....	26
Channel and frequencies.....	29
Regulations and Safety Warnings.....	35
Antenna Selection and Installation.....	35
Two Year Limited Warranty.....	36
Mounting Bracket Template.....	37

Table of Contents

List of Tables

Table 1 - Front panel button functions.....	7
Table 2 - Rear panel connector functions	8
Table 3 - Microphone button functions.....	9
Table 4 - Radio specifications	26
Table 5 - International Channel Frequencies and Channel Tag.....	29
Table 6 - USA Channel Frequencies and Channel Tag.....	31
Table 7 - Canadian Channel Frequencies and Channel Tag	33

Introduction

Features

- **Splashproof**
Meets the world standard JIS4 level. Being defined as no harmful influence by receiving a splash of water from any direction.
- **Large, LCD display**
- **Memory scan mode**
Lets you save channels to memory and monitor them in quick succession.
- **Transmitter Power Level Select**
Lets you boost the transmitter power from 1 watt to 25 watts for added transmission distance.
- **Battery level display and tone**
Sounds an alert tone if the battery voltage goes too high or too low.
- **Triple Watch Operation**
Checks the emergency channel 16 and channel 67 in the background.
- **All marine VHF channels for the International, U.S. and Canadian waters**
- **Siren Out**
- **Instant Channel**
- **Weather Mode**
- **One Touch 16/67 channel**

Manual overview

Conventions

This manual uses several different type styles to help you distinguish between different parts of the radio:

- **BOLD SMALL CAPITALS** indicates an actual button or knob on the radio or microphone.
- **Upper and Lower case bold** indicates a connector or label on the radio.
- *Italics* indicate text on the display, such as menu options, prompts, and confirmation messages.

Getting Started

What's included

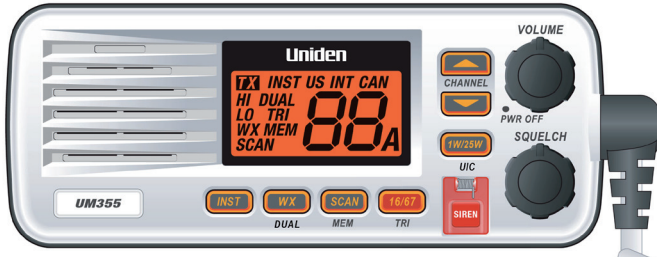

UM355 Radio

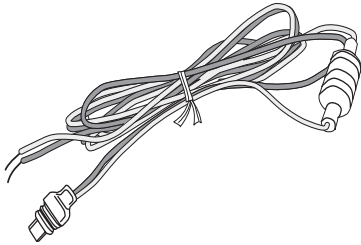

DC Power Cable

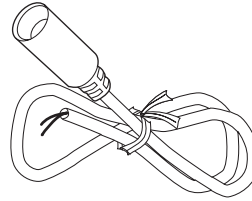

Accessory Cable

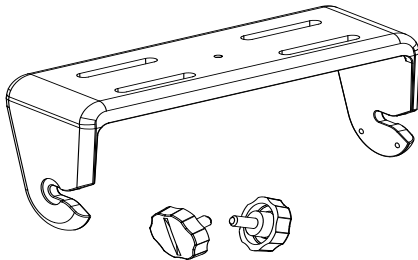

Mounting Bracket and knobs

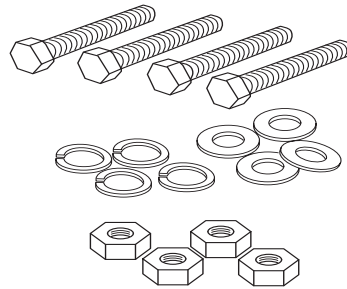

Mounting Hardware

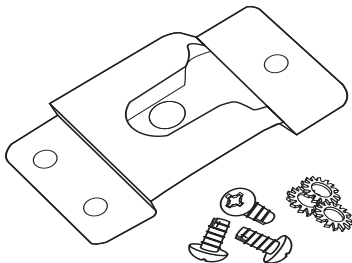

Microphone Hanger and Mounting Hardware

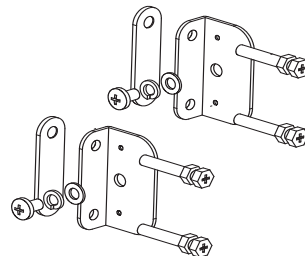

Flush Mount Bracket

Parts of the radio

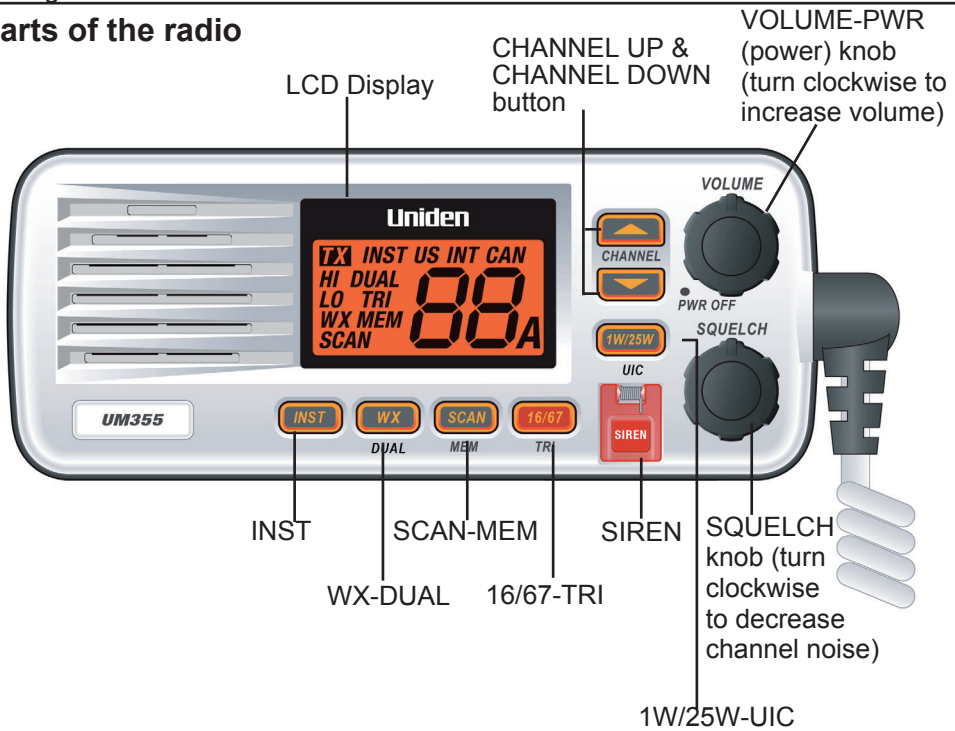

Table 1 - Front panel button functions

Button	Press to...	Press and hold to...
CHANNEL UP	Move up one channel at a time.	Move quickly up the channels.
CHANNEL DOWN	Move down one channel at a time.	Move quickly down the channels.
16/67-TRI	1st press: Go to Channel 16. 2nd press: Go to Channel 67. 3rd press: Go back to the original channel.	Go into Triple Watch
INST	Instant CH call	Instant CH programming
WX-DUAL	Select WX Channel	Select Dual Watch Function
SCAN-MEM	Select Scan function	Memory or remove scan channel
SIREN	Siren tone one cycle output	Siren tone output continually
1W/25W/UIC	Select transit power 1W or 25W	Select US, International or Canadian mode.

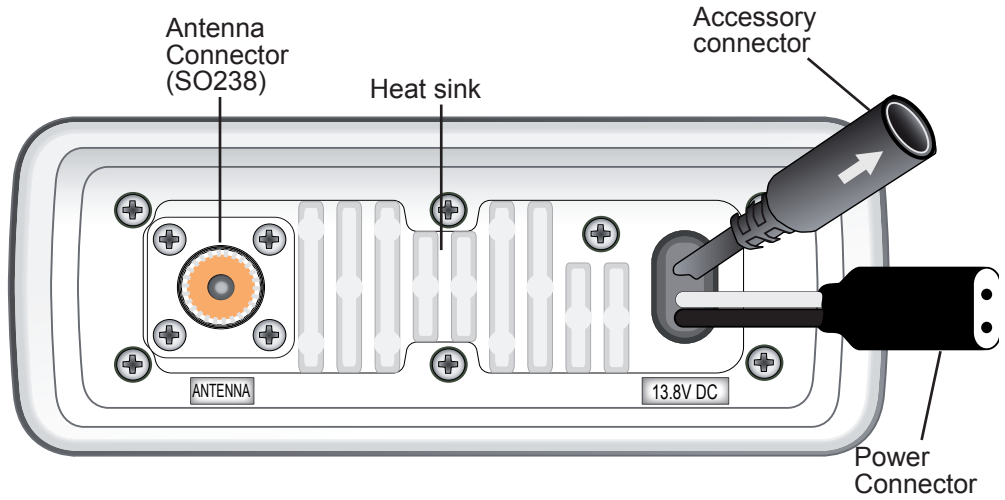

Table 2 - Rear panel connector functions

Connector	Connects to	For details, see
Antenna connector	External VHF antenna with a male PL259 (SO238) connector and 50 Ω impedance. Minimum 1.2m, 3dB rated antenna for sailboats, 2.4m, 6 dB rated for power boats.	Connecting the radio, page 21.
Power connector	Nominal 13.8 VDC power supply with negative ground (10.8 VDC to 15.6 VDC) (Red wire +, black wire -).	Connecting the radio, page 21.
Accessory connector	External speaker	Connecting accessories, page 23.



Table 3 - Microphone button functions

Button	Press to...	Press and hold to...
PUSH TO TALK	Cancel scanning and stay on a channel.	Talk on a channel.

How It Works

Turning on the radio

Turn the **VOLUME-PWR** knob clockwise to turn on the radio.

When it powers on, the radio selects the last channel used.

Setting the UIC Channel Mode (USA/CAN/INT)

Press and hold **1W/25W/UIC** to toggle between the modes, US, INT and CAN.

Note :If the UIC mode is changed, MRN CH is set to select previous CH in each mode. And Each of Scan mode, Triple/Dual Watch, EMG 16CH or 67CH mode and WX mode are canceled at this time.

How It Works

The UM355 has three basic modes of operation:

Operation mode	What it does:	Use it when:	To turn it on/off:
Normal mode	Monitors a single marine radio channel and lets you talk on that channel.	You want to talk to another station on a specific channel.	(default mode)
Scan mode	Monitors all the channels you save into memory.	You have a small group of channels you use most often and want to check them for traffic.	Press SCAN-MEM.
Weather mode	Monitors the selected weather channel	You want to hear the current or forecasted weather.	Press WX/DUAL

How It Works

In addition to the two main operation modes, the UM355 also provides two different “watch” modes which you can activate during any of the two basic modes. In the watch modes, the radio briefly checks for activity on a specific channel, then returns to its previous mode.

Watch mode	What it does:	Use it when:	To turn it on/off:
Triple Watch	Checks for activity on channels 16 and 67 every two seconds.	You want to monitor a channel yet maintain a watch on channels 16 and 67.	Press and hold the 16/67-TRI button for two seconds.
Dual Watch	Checks for activity on Instant Channel every two seconds.	You want to monitor a channel yet maintain a watch on Instant Channel.	Press and hold the WX/DUAL button for two seconds.

NOTE: You are required to monitor channel 16 whenever your boat is underway. You should have Triple Watch on at all times.

Normal mode operation

Normal mode monitors whatever channel you select, and you can transmit on that channel also. While using normal mode, the display lets you see the following information (not all indicators will display at the same time):

Icon	Detail
(TX)	This indicator is indicated only when the PTT key is pressed and the radio is sending a transmission.
LO / HI	This indicator is indicated whether the transmitting power is LO or HI. This is not indicated at WX mode and on the receiving only channels of MRN.
MEM	This indicator is indicated if the displayed channel is programmed into the memory for scanning.
INST	This indicator is indicated while current channel is instant channel.
SCAN	This indicator is indicated while in Scan mode.
TRI	This indicator is indicated while Triple Watch is enabled.
DUAL	This indicator is indicated while Dual Watch is enabled.
US / INT / CAN	This indicator is indicated the country mode that the channel is in.
WX	This indicator is indicated it is in the WX mode.
 (CH Indicators)	These indicators are indicated the present channel number.

Using the radio in normal mode

- To transmit, press and hold **PUSH TO TALK** on the microphone. Release the button when you are finished talking.
- For the best sound quality, hold the microphone about two inches from your mouth while you're talking.
- Press **CHANNEL UP** on the radio to move up one channel at a time. Press and hold either button to scroll quickly up the channels.
- Press **CHANNEL DOWN** on the radio to move down one channel at a time. Press and hold either button to scroll quickly down the channels.
- To change the transmit power, press **1W/25W/UIC**. The transmit power switches between 1 watt and 25 watts each time you press **1W/25W/UIC**.

Normal mode with Triple and Dual Watch

If you activate Triple Watch while operating in normal mode, the radio checks channels 16 and 67 every two seconds; with Dual Watch turned on, the radio only checks Instant Channel. The radio will not check channels 16 or 67 while you are actively transmitting; it waits until your transmission is finished and then checks the channels.

Press and hold the **WX-DUAL** or **16/67-TRI** button (on the radio) for two seconds to turn Triple/Dual Watch on or off.

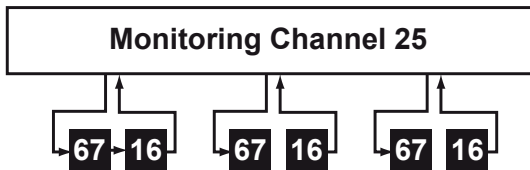

Every 2 seconds, the radio checks channels 67 & 16.
with Triple Watch on

Scan mode

You can save channels into memory and then use scan mode to monitor those channels. When the radio detects a signal on a channel, it pauses on that channel as long as the signal is received; when the transmission stops, the radio will continue scanning.

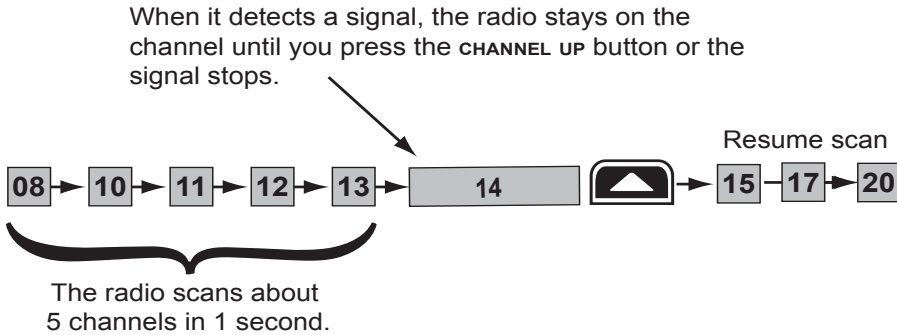

Using the radio in scan mode

- You cannot transmit while in scan mode.
- You must have two or more channels in memory to start a scan.
- To save a channel into memory, select the channel, then press and hold **SCAN-MEM** for two seconds. "MEM" icon will show on the display.
- To remove a channel from memory, set the radio to that channel, then press and hold **SCAN-MEM** for two seconds. "MEM" icon will no longer show on the display.
- To activate scan mode, press **SCAN-MEM**. Press **SCAN-MEM** again to return to the previous mode.
- When the radio automatically stops on a channel, press **CHANNEL UP** to leave that channel and resume scanning.
- To end the scan, press the microphone's **PUSH TO TALK** button. The radio remains on the last scanned channel.

Scan mode with Triple and Dual Watch

If you activate Triple Watch while operating in scan mode, the radio checks channels 16 and 67 every two seconds, then goes on to scan the next channel; with Dual Watch turned on, the radio only checks Instant Channel

Press and hold **WX-DUAL** or **16/67-TRI** (on the radio) for two seconds to turn Triple/Dual Watch on or off. Press **SCAN-MEM** key to turn Scan on or off.

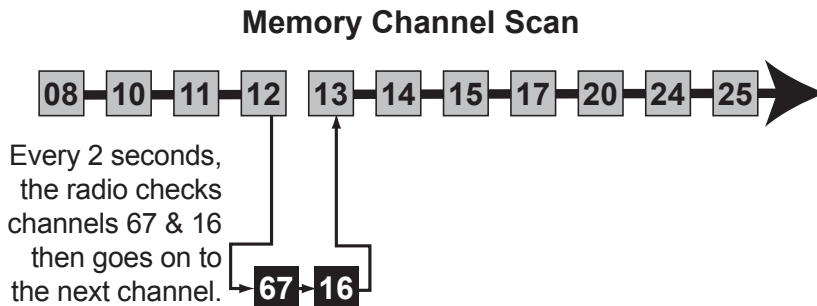

with Triple Watch on

Weather Mode (WX)

Press **WX-DUAL**. The channel display will show 67CH as the initial (factory) default. The user can use the **CHANNEL UP** or **CHANNEL DOWN** to move through the 5 WX channels to find the active channel in their local area.

Note: The last selected WX channel is displayed when the radio is turned back to WX mode.

Using Your Radio

Setting the Volume

Turn the volume knob clockwise to increase the speaker volume; turn it counter-clockwise to decrease the volume.

Setting the Squelch Level

The squelch feature reduces the level of static on the speaker by filtering out the background channel noise. At the lowest squelch level, the speaker plays all radio signals, including any noise on the channel. Setting the squelch level higher filters out channel noise and lets only actual radio transmissions through.

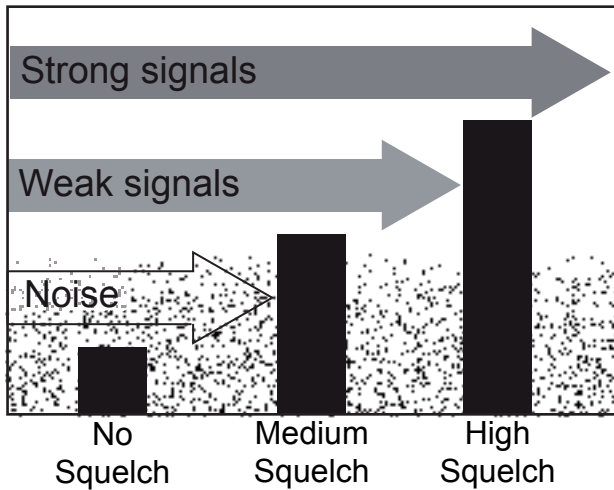

While listening to a channel, adjust the **SQUELCH** knob until the noise is filtered out and you can only hear the transmission. If you switch to a channel with a lot of noise or with a weak transmission, you may need to adjust the squelch level again.

NOTE: Setting the squelch level too high may prevent you from hearing weaker transmissions. If you are having difficulty hearing a transmission, try setting the squelch level lower.

Changing the channel

Press the **CHANNEL UP** or **CHANNEL DOWN** buttons briefly to scroll through the channels one channel at a time. Press and hold the channel up or down button to quickly scroll through the channels.

Making a transmission

To make a transmission, press and hold the microphone **PUSH TO TALK** button. Release the **PUSH TO TALK** button when you're finished talking to let the other party respond.

- To prevent stuck microphone problems or situations where the **PUSH TO TALK** button is pushed accidentally, the radio limits your talk time to 5 minutes in a single transmission.
- For the best sound quality, hold the microphone about two inches away from your mouth.
- You cannot transmit while the radio is in scan mode.
- See the channel list on page 29 for a list of receive-only channels.

Boosting the transmission power

In most situations, the 1 Watt transmission power is all you need. If you find yourself far away from other stations and have trouble getting a response, you may need to boost the transmission power from 1 Watt to 25 Watts:

1. Select the channel you want to transmit on.
2. Press **1W/25W/UIC**. The display shows "HI" in the upper left hand corner.
3. The transmit power remains at 25 Watts until you change the setting back. Press **1W/25W/UIC**. The display shows "LO".

NOTE: Don't forget to change the transmission setting back to 1 Watt when you move closer to other stations.

NOTE: By default, when you change to channel 16, the radio automatically boosts the power to 25 Watts. Be sure to change the power back to 1 Watt if you are not making an emergency transmission.

Some channels limit the power of transmission to 1 Watt so that there is less interference between boaters attempting to use the channel at the same time. If you switch to one of these channels, the radio changes back to 1 Watt automatically. See the channel list on page 29 for a list of power-restricted channels.

Instant Channel

Only one channel can be set up as Instant CH in idle mode. Press and hold **INST**, the current channel will be programmed to Instant CH, this "INST" icon will display. The previous entry of Instant CH is deleted and current CH is set up as Instant CH.

Using Your Radio

Press **INST** on a certain CH to toggle between the Instant CH and the previously selected channel.

This key functions similar to the Emergency Channel 16CH and 67CH.

Note:

Pressing **INST** key in Tripe / Dual Watch, or Scan Mode, these mode are canceled and Instant CH is called in normal RX mode.

Siren Out

Pressing **SIREN** will activate the Siren Out function. This function will generate Siren 3 times.

Press and hold **SIREN** to generate continuous Siren. To stop press any key.

Changing display and sound options

Dimmer

Your radio has a dimmer function and the setting can be changed between Off, Low, Mid and High. Turn on the radio while pressing the **INST** key, the dimmer function will be switched High to Off, Off to Low, Low to Mid, Mid to High.

Turning the key beep on and off

Key beep is the tone that sounds when you press a key or a button.

Turn on the radio while pressing the **CHANNEL UP** or **CHANNEL DOWN**, the Key Beep function will be switched On or Off.

Installing the Hardware

Mounting the radio

The UM355 can sit at any angle in the mounting bracket so it can easily accommodate the best location. First, determine the best place to mount the radio. For optimum performance, find a location that can:

- Properly support the weight of the radio, approximately 2.2 pounds or 1.1 kilograms. You may need to use some type of anchor with the mounting screws to hold the radio, depending on the surface.
 - Keep the battery leads as short as possible.
 - Keep the antenna lead-in wire as short as possible.
 - Allow free air flow around the heat sink on the rear of the radio.
 - Avoid interference with the ship's compass.
1. Install the radio into the mounting bracket, and connect the power cable and accessory cable.

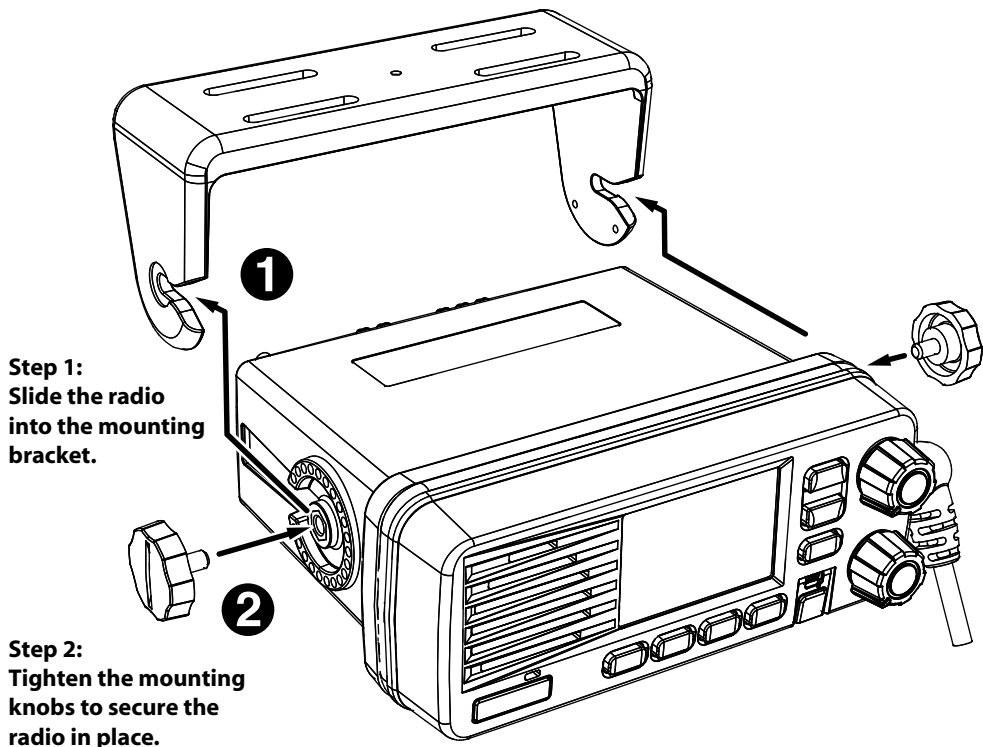

Installing the Hardware

2. Position the radio into the desired location. Mark the edges of the bracket on the mounting surface.
3. Remove the mounting bracket drill template from the back of the manual, and use the template to mark the drill holes on the mounting surface.
4. Drill the holes for the mounting bracket; be sure to follow any special requirements of the mounting surface.
5. Remove the bracket from the radio, and use the mounting hardware to secure the bracket to the mounting surface.

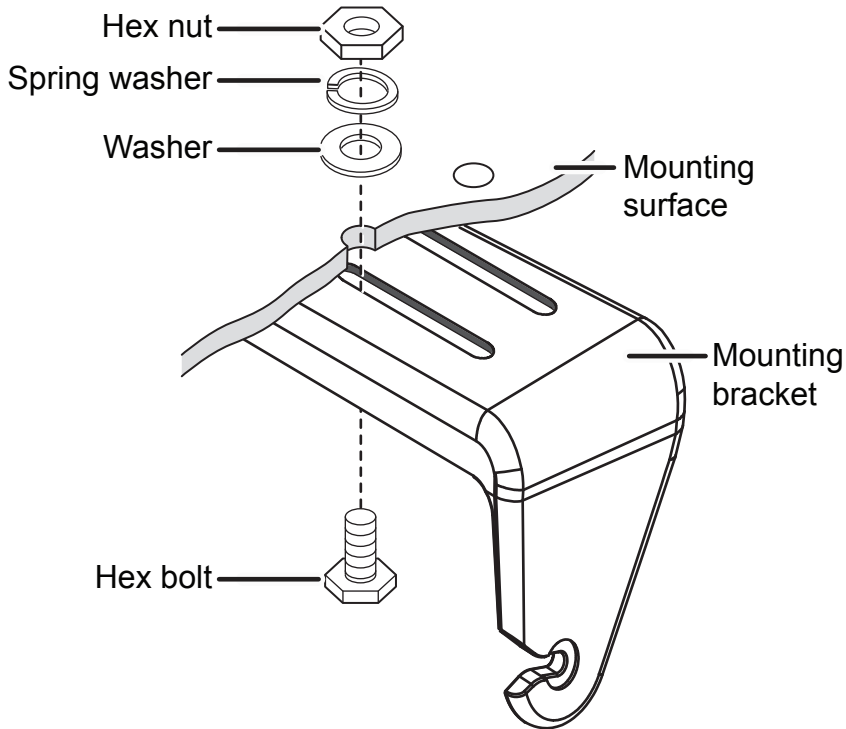

6. Install the radio back into the mounting bracket.

Installing the Flush Mount Bracket

A FLUSH MOUNT is available for mounting the transceiver to a flat surface such as an instrument panel.

CAUTION: KEEP the transceiver and microphone at least 1 meter away from your vessel's magnetic navigation compass.

1. Carefully cut a hole into the instrument panel (or wherever you plan to mount the transceiver.). Refer to page 28 for recommended dimensions.
2. Slide the transceiver through the hole as shown in the image on the right.
3. Attach the clamps on either side of the transceiver with 2 supplied bolts (5x8 mm). Make sure that the clamps align parallel to the transceiver body.

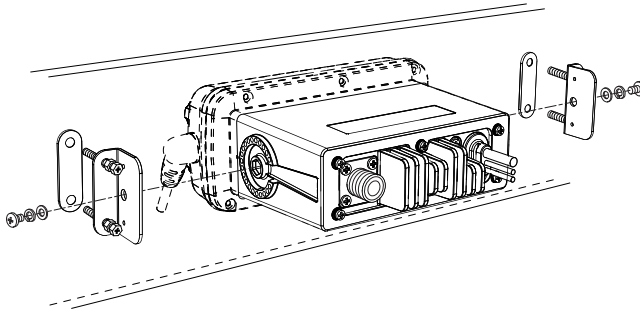
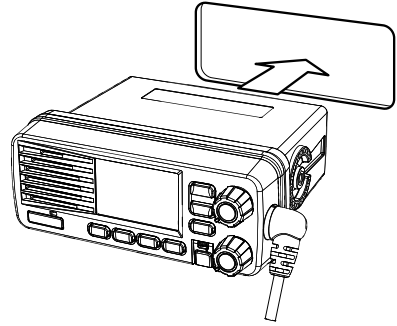

4. Tighten the end bolts on the clamps (rotate clockwise) so that the clamps press firmly against the inside of the instrument control panel.

- 5 Tighten the locking nuts (rotate clockwise) so that the transceiver is securely mounted in position as below.

6. Connect the antenna and power cable, then return the instrument control panel to its original place.

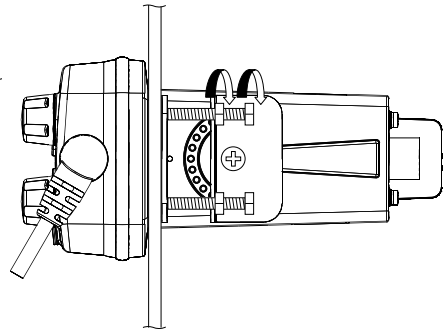
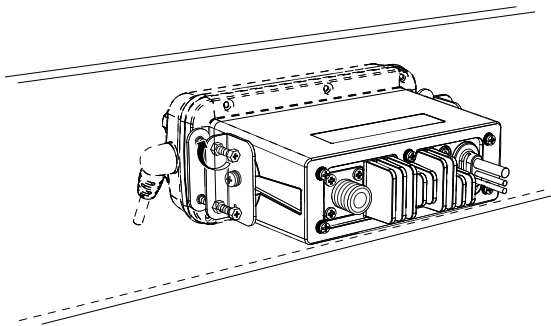

Connecting the radio

To operate correctly, your UM355 requires two electrical connections:

- providing it with power from the boat's electrical system
- connecting a VHF-FM marine antenna to the antenna connector

Power supply requirements	VHF antenna requirements
Nominal 13.8 VDC power supply with a negative ground (10.8 VDC to 15.6 VDC). Power leads should be kept as short as possible. A direct connection to the power supply is ideal. Minimum of #14 AWG copper wire for extensions up to 6m, 12 AWG wire for extensions from 6m to 10m, or 10 AWG wire for extensions from 10 to 18m	Male PL-259 connector 50 Ω impedance Minimum 1.2m, 3 dB rated antenna for sailboats or 2.4m, 6dB rated antenna for powerboats Minimum RG-58 lead-in wire for antenna leads up to 6m to 10m, RG-8X for antenna leads from 6m to 10m, or RG-8U for antenna leads from 10m to 18m.

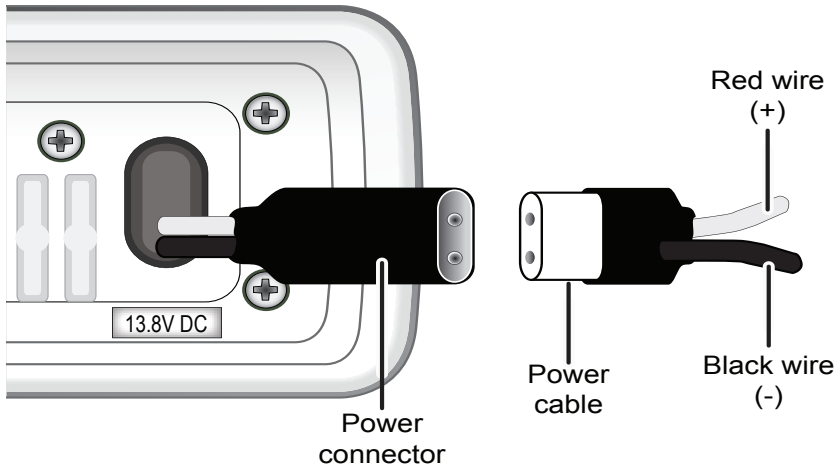

Installing the Hardware

1. Connect the BLACK wire of the included **power cable** to the NEGATIVE (-) side of your power source.
2. Connect the RED wire of the included **power cable** to the POSITIVE (+) side of your power source.
3. Connect the **power cable** to the **power connector** on the back of the UM355. (The power connector only fits one way.)
4. NOTE: To extend the life of the radio, use waterproof tape to seal electrical connections.
5. Install your antenna according to the manufacturer's instructions.
6. See Antenna Selection and Installation on page 35 for more details.
7. Connect the PL-259 connector from the antenna lead-in wire to the SO238 connector labeled **ANTENNA** on the back of the UM355.

Radio connector,
SO238 (female)
PL-259

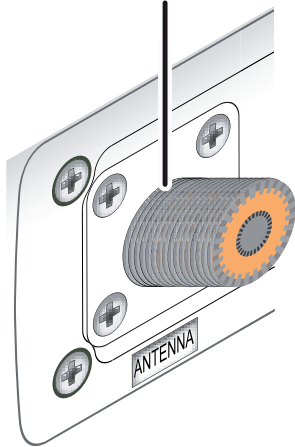

Antenna lead-in
connector,
male PL-259

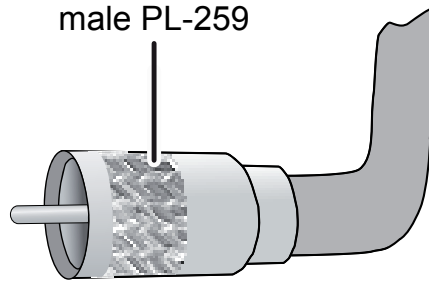

Connecting Accessories

Connecting to an external speaker

You can use an external speaker to monitor the radio from a different part of your boat or in a noisy environment. If you adjust the **VOLUME-PWR** knob on the radio, it will also adjust the external speaker volume.

The UM355 supports an external speaker with the following specifications:

- Minimum impedance of 4 Ohms
- Minimum power handling of 10 Watts

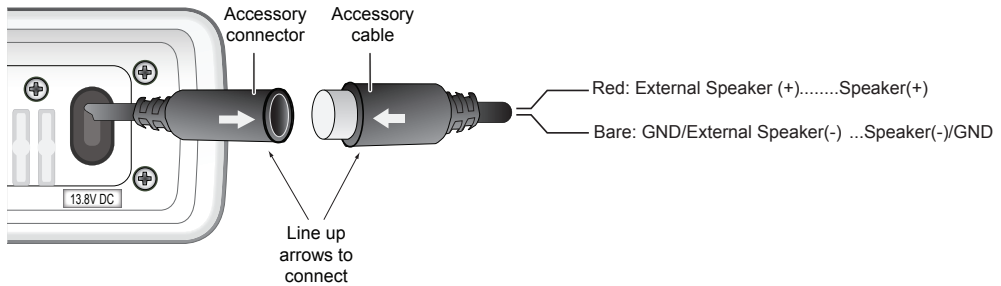

1. Disconnect the **accessory cable** from the accessory connection on the radio.
2. Connect the BARE wire of the **accessory cable** to the GROUND WIRE of your external speaker.
3. Connect the RED wire of the **accessory cable** to the POSITIVE (+) WIRE of your external speaker.
4. Be certain all wire connections are secure and that all open wires are adequately covered.
5. If you are finished connecting all external accessories, line up the arrows on the side of the **accessory cable** and connector and connect the **accessory cable** to the **accessory connector** on the back of the UM355.

NOTE: To extend the life of the radio, use waterproof tape to seal electrical connections.

Maintenance and Troubleshooting

Due to its rugged design, the UM355 requires very little maintenance. However, it is a precision electronic instrument, so you should follow a few precautions:

- If the antenna has been damaged, you should not transmit except in the case of an emergency. A defective antenna may cause damage to your radio.
- You should arrange for periodic performance checks with your Uniden dealer.

Common questions

Problem	Things to Try
The radio won't power on.	Check the power connections. Check the fuse. Check the master battery switch and branch circuit that connect to the radio.
The radio won't transmit.	Make sure you are not in scan mode. Make sure you are not trying to transmit on a receive-only channel (see the channels and frequency tables starting on page 29). Make sure you are transmitting at the correct power level for this channel (see the channels and frequency tables starting on page 29). Make sure the duration of each transmission is less than 5 minutes.
Noise comes out of the speaker all the time	Adjust the squelch level; it is probably too low.
I can't hear anything (no volume) from the speaker.	Adjust the squelch level; it is probably too high.
I can transmit, but no one can hear me.	Check your UIC channel settings (see Setting the UIC channel mode (USA/CAN/INT) on page 10).
I can't read the display.	Adjust the dimmer level (see page 17)
The display is too bright at night.	Adjust the dimmer level level. (see page 17)
Where can I find my radio's serial number?	Look on the bottom side of the radio

Engine Noise Suppression

Interference from the noise generated by the electrical systems of engines is sometimes a problem with radios. The UM355 has been designed to be essentially impervious to ignition noise and alternator noise. However, in some installations it may be necessary to take measures to further reduce the effect of noise interference. The UM355 radio DC battery wires, antenna lead, and accessory cables should be routed away from the engine and engine compartment, and from power cabling carrying high currents. In severe cases of noise interference, it may be necessary to install a noise suppression kit. Contact the dealer where you purchased the radio for more information.

Specifications

Table 4 - Radio specifications

(All specifications are subject to change without notice.)

General	
Controls	Volume-Pwr, Squelch
Status Indicators	Transmit power, Scan mode, Triple Watch mode, Dual Watch mode, Battery High, Battery low, USA, CAN, INT, Memory, Message, Weather band and Channel Display
Display	LCD
Buttons	1W/25W/UIC, Channel UP, Channel DOWN, INST, WX-DUAL, 16/67-TRI, SIREN, and SCAN/MEM
Connectors and Cables	Antenna, accessory, and DC power
Size	H 66 mm x W 162 mm x L 128 mm H 2.60 inches x W 6.38 inches x L 5.04 inches
Weight	1.0 kg (2.2 pounds)
Supply Voltage	Nominal 13.8V DC, negative ground (10.8 VDC to 15.6 VDC)
Standard Accessories	Mounting bracket and hardware, microphone hanger,
Antenna Impedance	50 Ω nominal
Microphone	Rugged 2 k Ω condenser mic element with coiled cord
Speaker	1.77 inch, 8 Ω
Operating Temperature Range	-15 °C to + 55 °C (+5°F to +131°F)
Shock and Vibration	Meets or exceeds EIA standards, RS152B and RS204C
AS/NZS Approvals	Type accepted under AS/NZS 4415.2:2003 of the Rules.
Transmitter	
Power Output	1 watt or 25 watt (user selectable)
Power Requirement	25 watts output: 6A@13.8V DC
Modulation	\pm 5 kHz deviation
Hum and Noise Signal-to-Noise	45 dB@1 kHz with 3 kHz deviation with 1000 Hz modulating frequency (nominal)

Specifications

General	
Audio Distortion	Less than 8% with 3 kHz deviation with 1000 Hz modulating frequency
Spurious Suppression	-45 dBm @ Hi, -55 dBm @ Lo
Output Power Stabilization	Built-in automatic level control (ALC)
Frequency Range	156 to 158 MHz
Frequency Stability	$\pm 1.5\text{kHz}$ @ -15°C to $+ 55^{\circ}\text{C}$
Receiver	
Frequency Range	156 to 163 MHz
Sensitivity	0.25 μV for 12 dB SINAD (nominal)
Circuit	Dual Conversion Super Heterodyne PLL
Squelch Sensitivity	0.2 μV Threshold
Spurious Response	75 dB (nominal)
Adjacent Channel Selectivity	78 dB @ $\pm 25\text{ kHz}$ (nominal)
Audio Output Power	2.5 watts (10% Distortion, 8 Ω load)
Power Requirement	230mA @ 13.8V DC at squelched, 440 mA @ 13.8V DC at maximum audio output
IF Frequencies	1st 41.925 MHz, 2nd 455 kHz

Flush Mount Bracket - Recommended size

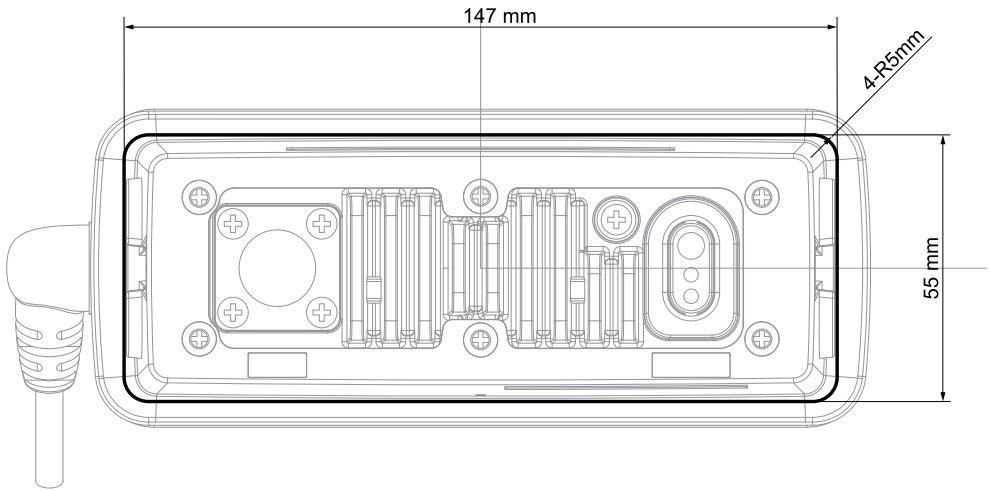

Channel and frequencies

Table 5 - International Channel Frequencies and Channel Tag

Ch No.	RX Freq	TX Freq	Status	Full Name
1	160.6500	156.0500	Duplex	Marine operator
2	160.7000	156.1000	Duplex	Marine operator
3	160.7500	156.1500	Duplex	Marine operator
4	160.8000	156.2000	Duplex	Marine operator
5	160.8500	156.2500	Duplex	Marine operator
6	156.3000	156.3000	Simplex	Inter-ship safety
7	160.9500	156.3500	Duplex	Marine operator
8	156.4000	156.4000	Simplex	Commercial (ship-ship)
9	156.4500	156.4500	Simplex	Boater calling channel
10	156.5000	156.5000	Simplex	Commercial
11	156.5500	156.5500	Simplex	Vessel traffic system
12	156.6000	156.6000	Simplex	Vessel traffic system
13	156.6500	156.6500	Simplex	Bridge to bridge
14	156.7000	156.7000	Simplex	Vessel traffic system
15	156.7500	156.7500	Simplex, 1W	Environmental
16	156.8000	156.8000	Simplex	Distress, Safety, Calling
17	156.8500	156.8500	Simplex, 1W	Govt maritime control
18	161.5000	156.9000	Duplex	Port operation
19	161.5500	156.9500	Duplex	Commercial
20	161.6000	157.0000	Duplex	Port operation
21	161.6500	157.0500	Duplex	Port operation
22	161.7000	157.1000	Duplex	Port operation
23	161.7500	157.1500	Duplex	Marine operator
24	161.8000	157.2000	Duplex	Marine operator
25	161.8500	157.2500	Duplex	Marine operator
26	161.9000	157.3000	Duplex	Marine operator
27	161.9500	157.3500	Duplex	Marine operator
28	162.0000	157.4000	Duplex	Marine operator
60	160.6250	156.0250	Duplex	Marine operator
61	160.6750	156.0750	Duplex	Marine operator
62	160.7250	156.1250	Duplex	Marine operator
63	160.7750	156.1750	Duplex	Marine operator
64	160.8250	156.2250	Duplex	Marine operator
65	160.8750	156.2750	Duplex	Marine operator
66	160.9250	156.3250	Duplex	Marine operator
67	156.3750	156.3750	Simplex	Bridge to bridge
68	156.4250	156.4250	Simplex	Non commercial
69	156.4750	156.4750	Simplex	Non commercial
70	(156.5250	156.5250)	DSC Only	DSC

Table 5 - International Channel Frequencies and Channel Tag (cont'd)

Ch No.	RX Freq	TX Freq	Status	Full Name
71	156.5750	156.5750	Simplex	Non commercial
72	156.6250	156.6250	Simplex	Non commercial
73	156.6750	156.6750	Simplex	Port operation
74	156.7250	156.7250	Simplex	Port operation
75	156.7750	156.7750	Simplex, 1W	Port operation
76	156.8250	156.8250	Simplex, 1W	Port operation
77	156.8750	156.8750	Simplex	Port operation (ship-ship)
78	161.5250	156.9250	Duplex	Port operation
79	161.5750	156.9750	Duplex	Port operation
80	161.6250	157.0250	Duplex	Port operation
81	161.6750	157.0750	Duplex	Port operation
82	161.7250	157.1250	Duplex	Port operation
83	161.7750	157.1750	Duplex	Port operation
84	161.8250	157.2250	Duplex	Marine operator
85	161.8750	157.2750	Duplex	Marine operator
86	161.9250	157.3250	Duplex	Marine operator
87	157.3750	157.3750	Simplex	Marine operator
88	157.4250	157.4250	Simplex	Marine operator

Specifications

Table 6 - USA Channel Frequencies and Channel Tag

Ch No.	RX Freq (MHz)	TX Freq (MHz)	Status	Full Name
1 "A"	156.0500	156.0500	Simplex	Vessel traffic system/ Commercial
5 "A"	156.2500	156.2500	Simplex	Vessel traffic system / Commercial
6	156.3000	156.3000	Simplex	Inter-ship safety
7 "A"	156.3500	156.3500	Simplex	Commercial
8	156.4000	156.4000	Simplex	Commercial
9	156.4500	156.4500	Simplex	Non commercial
10	156.5000	156.5000	Simplex	Commercial
11	156.5500	156.5500	Simplex	Vessel traffic system
12	156.6000	156.6000	Simplex	Vessel traffic system
13	156.6500	156.6500	Simplex, 1W	Bridge to bridge
14	156.7000	156.7000	Simplex	Vessel traffic system
15	156.7500	Inhibit	Receive Only	Environmental
16	156.8000	156.8000	Simplex	Distress, Safety, Calling
17	156.8500	156.8500	Simplex, 1W	Govt maritime control
18 "A"	156.9000	156.9000	Simplex	Commercial
19 "A"	156.9500	156.9500	Simplex	Commercial
20	161.6000	157.0000	Duplex	Port operation
20 "A"	157.0000	157.0000	Simplex	Port operation
21 "A"	157.0500	157.0500	Simplex	Coast guard only
22 "A"	157.1000	157.1000	Simplex	Coast guard
23 "A"	157.1500	157.1500	Simplex	Coast guard only
24	161.8000	157.2000	Duplex	Marine operator
25	161.8500	157.2500	Duplex	Marine operator
26	161.9000	157.3000	Duplex	Marine operator
27	161.9500	157.3500	Duplex	Marine operator
28	162.0000	157.4000	Duplex	Marine operator
63 "A"	156.1750	156.1750	Simplex	Vessel traffic system
65 "A"	156.2750	156.2750	Simplex	Port operation
66 "A"	156.3250	156.3250	Simplex	Port operation
67	156.3750	156.3750	Simplex, 1W	Bridge to bridge
68	156.4250	156.4250	Simplex	Non commercial
69	156.4750	156.4750	Simplex	Non commercial
70	(156.5250	156.5250)	DSC Only	DSC
71	156.5750	156.5750	Simplex	Non commercial
72	156.6250	156.6250	Simplex	Non commercial (ship-ship)
73	156.6750	156.6750	Simplex	Port operation
74	156.7250	156.7250	Simplex	Port operation
75	156.775	156.7750	Simplex, 1W	Port operation

Specifications

Table 6 - USA Channel Frequencies and Channel Tag (cont'd)

Ch No.	RX Freq (MHz)	TX Freq (MHz)	Status	Full Name
76	156.825	156.8250	Simplex, 1W	Port operation
77	156.8750	156.8750	Simplex, 1W	Port operation (ship-ship)
78 "A"	156.9250	156.9250	Simplex	Non commercial
79 "A"	156.9750	156.9750	Simplex	Commercial
80 "A"	157.0250	157.0250	Simplex	Commercial
81 "A"	157.0750	157.0750	Simplex	Government
82 "A"	157.1250	157.1250	Simplex	Government
83 "A"	157.1750	157.1750	Simplex	Coast guard
84	161.8250	157.2250	Duplex	Marine operator
85	161.8750	157.2750	Duplex	Marine operator
86	161.9250	157.3250	Duplex	Marine operator
87	157.3750	157.3750	Simplex	Marine operator
88	157.4250	157.4250	Simplex	Commercial (ship-ship)

The "A" indicates simplex use of the ship station transmit side of an international duplex channel, and that operations are different from that of international operations on that channel.

Specifications

Table 7 - Canadian Channel Frequencies and Channel Tag

Ch No.	RX Freq	TX Freq	Status	Full Name
1	160.6500	156.0500	Duplex	Marine operator
2	160.7000	156.1000	Duplex	Marine operator
3	160.7500	156.1500	Duplex	Marine operator
4 "A"	156.2000	156.2000	Simplex	Canadian coast guard
5 "A"	156.2500	156.2500	Simplex	Vessel traffic system
6	156.3000	156.3000	Simplex	Inter-ship safety
7 "A"	156.3500	156.3500	Simplex	Commercial
8	156.4000	156.4000	Simplex	Commercial
9	156.4500	156.4500	Simplex	Boater calling channel
10	156.5000	156.5000	Simplex	Commercial
11	156.5500	156.5500	Simplex	Vessel traffic system
12	156.6000	156.6000	Simplex	Vessel traffic system
13	156.6500	156.6500	Simplex, 1W	Bridge to bridge
14	156.7000	156.7000	Simplex	Vessel traffic system
15	156.7500	156.7500	Simplex	Environmental
16	156.8000	156.8000	Simplex	Distress, Safety, Calling
17	156.8500	156.8500	Simplex, 1W	State control
18 "A"	156.9000	156.9000	Simplex	Commercial
19 "A"	156.9500	156.9500	Simplex	Canadian coast guard
20	161.6000	157.0000	Duplex, 1W	Port operation
21 "A"	157.0500	157.0500	Simplex	Canadian coast guard
22 "A"	157.1000	157.1000	Simplex	Canadian coast guard
23	161.7500	157.1500	Duplex	Marine operator
24	161.8000	157.2000	Duplex	Marine operator
25	161.8500	157.2500	Duplex	Marine operator
26	161.9000	157.3000	Duplex	Marine operator
27	161.9500	157.3500	Duplex	Marine operator
28	162.0000	157.4000	Duplex	Marine operator
60	160.6250	156.0250	Duplex	Marine operator
61 "A"	156.0750	156.0750	Simplex	Canadian coast guard
62 "A"	156.1250	156.1250	Simplex	Canadian coast guard
63 "A"	156.1750	156.1750	Simplex	Port operation
64	160.8250	156.2250	Duplex	Marine operator
64 "A"	156.2250	156.2250	Simplex	Port operation
65 "A"	156.2750	156.2750	Simplex	Port operation
66 "A"	156.3250	156.3250	Simplex, 1W	Port operation
67	156.3750	156.3750	Simplex	Bridge to bridge
68	156.4250	156.4250	Simplex	Non commercial
69	156.4750	156.4750	Simplex	Non commercial
70	(156.5250	156.5250)	DSC Only	DSC

Specifications

Table 7- Canadian Channel Frequencies and Channel Tag (cont'd)

Ch No.	RX Freq	TX Freq	Status	Full Name
71	156.5750	156.5750	Simplex	Non commercial
72	156.6250	156.6250	Simplex	Non commercial
73	156.6750	156.6750	Simplex	Port operation
74	156.7250	156.7250	Simplex	Port operation
75	156.7750	156.7750	Simplex, 1W	Port operation
76	156.8250	156.8250	Simplex, 1W	Port operation
77	156.8750	156.8750	Simplex, 1W	Port operation
78 "A"	156.9250	156.9250	Simplex	Inter ship
79 "A"	156.9750	156.9750	Simplex	Inter ship
80 "A"	157.0250	157.0250	Simplex	Inter ship
81 "A"	157.0750	157.0750	Simplex	Canadian coast guard
82 "A"	157.1250	157.1250	Simplex	Canadian coast guard
83	161.7750	157.1750	Duplex	Canadian coast guard
83 "A"	157.1750	157.1750	Simplex	Canadian coast guard
84	161.8250	157.2250	Duplex	Marine operator
85	161.8750	157.2750	Duplex	Marine operator
86	161.9250	157.3250	Duplex	Marine operator
87	157.3750	157.3750	Simplex	Port operation
88	157.4250	157.4250	Simplex	Port operation

The "A" indicates simplex use of the ship station transmit side of an international duplex channel, and that operations are different from that of international operations on that channel.

Regulations and Safety Warnings

Antenna Selection and Installation

Your UM355 has been designed to accommodate all of the popular marine VHF antennas. However, the selection and the proper installation of the antenna is the responsibility of the user or installer.

The antenna used with this radio should be installed using the following guidelines to ensure a safe distance between the antenna and persons close by.

- Small whip antennas (3 dB) or smaller should be installed with at least 1m away from any area where people are likely to be.
- Larger antennas (6 dB or 9 dB) should be installed with at least 2m away.
- While the radio is transmitting, do not come closer to the antenna than the recommended safe distance.
- Do not touch the antenna when the radio is powered on and might begin transmitting.

Two Year Limited Warranty

UNIDEN UM355 VHF

IMPORTANT Satisfactory evidence of the original purchase is required for warranty service
Please refer to our Uniden website for any details or warranty durations offered in addition to those contained below.

Warrantor

The warrantor is Uniden Australia Pty Limited ABN 58 001 865 498 (“Uniden Aust”).

Terms of Warranty

Uniden Aust warrants to the original retail purchaser only that the UM355 VHF (“the Product”), will be free from defects in materials and craftsmanship for the duration of the warranty period, subject to the limitations and exclusions set out below.

Warranty Period

This warranty to the original retail purchaser is only valid in the original country of purchase for a Product first purchased either in Australia or New Zealand.

Product	2 Years
Accessories	1 Year

If a warranty claim is made, this warranty will not apply if the Product is found by Uniden to be:

- (A) Damaged or not maintained in a reasonable manner or as recommended in the relevant Uniden Owner’s Manual;
- (B) Modified, altered or used as part of any conversion kits, subassemblies or any configurations not sold by Uniden Aust;
- (C) Improperly installed contrary to instructions contained in the relevant Owner’s Manual
- (D) Repaired by someone other than an authorized Uniden Repair Agent in relation to a defect or malfunction covered by this warranty; or
- (E) Used in conjunction with any equipment, parts or a system not manufactured by Uniden.

Parts Covered

This warranty covers the Product and included accessories.

User-generated Data

This warranty does not cover any claimed loss of or damage to user-generated data (including but without limitation phone numbers, addresses and images) that may be stored on your Product.

Statement of Remedy

If the Product is found not to conform to this warranty as stated above, the Warrantor, at its discretion, will either repair the defect or replace the Product without any charge for parts or service. This warranty does not include any reimbursement or payment of any consequential damages claimed to arise from a Product’s failure to comply with the warranty.

Our goods come with guarantees that cannot be excluded under the Australian Consumer Law. You are entitled to a replacement or refund for a major failure and for compensation for any other reasonably foreseeable loss or damage. You are also entitled to have the goods repaired or replaced if the goods fail to be of acceptable quality and the failure does not amount to a major failure.

This warranty is in addition to and sits alongside your rights under either the COMPETITION AND CONSUMER ACT 2010 (Australia) or the CONSUMER GUARANTEES ACT (New Zealand) as the case may be, none of which can be excluded.

Procedure for Obtaining Warranty Service

Depending on the country in which the Product was first purchased, if you believe that your Product does not conform with this warranty, you should deliver the Product, together with satisfactory evidence of your original purchase (such as a legible copy of the sales docket) to Uniden at the addresses shown below. You should contact Uniden regarding any compensation that may be payable for your expenses incurred in making a warranty claim. Prior to delivery, we recommend that you make a backup copy of any phone numbers, images or other data stored on your Product, in case it is lost or damaged during warranty service.

UNIDEN AUSTRALIA PTY LTD

Service Division
345 Princes Highway,
Rockdale, NSW 2216
Phone number: 1300 366 895
Email address: custservice@uniden.com.au





Uniden®

© 2014 Uniden Australia Pty Limited Printed in Vietnam U01UT651ZZZ(0)