

MAX LOAD RATING: 4 kg

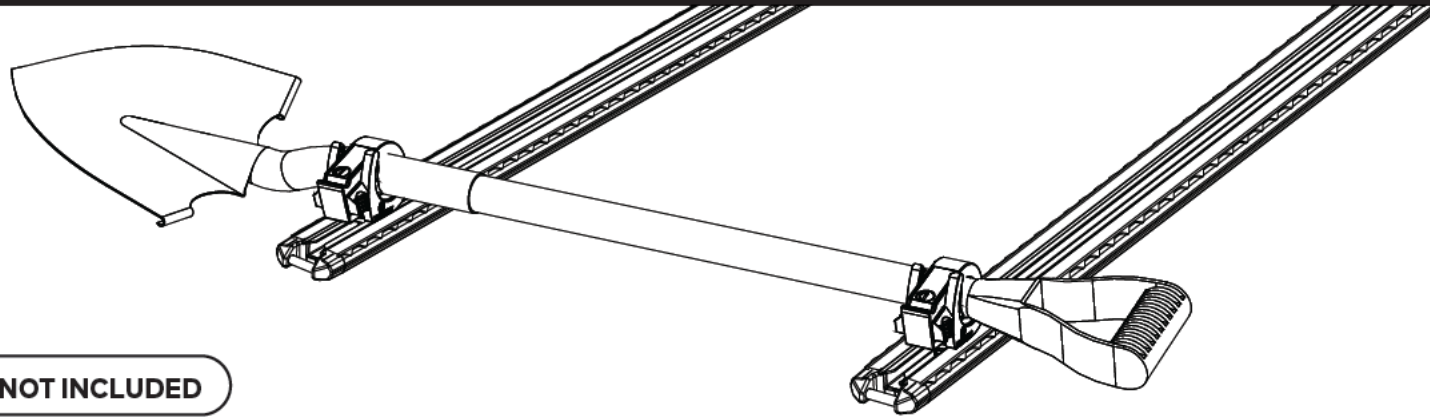

CROSSBARS AND SHOVEL NOT INCLUDED

FIRST TIME INSTALLATION

- Please read instructions carefully before installation.
- Check the contents of kit. Contact your YAKIMA dealer if any parts appear missing or damaged.
- Clean your roof rack/platform prior to fitting the YAKIMA AceO'Spades Shovel Holder Kit.
- Place these instructions in the vehicle's glove box after installation is complete.

KIT CONTENTS

ITEM	COMPONENT	QTY
1.	Shovel Holder Assembly	x2
2.	16 mm Socket Head Cap Screw	x2
3.	20 mm Socket Head Cap Screw	x2
4.	25 mm Socket Head Cap Screw	x2
5.	Star Washer	x2
6.	Deformed Nut	x2
7.	Slot Nut	x2
8.	Allen Key	x1
9.	YAKIMA Key Set	x1

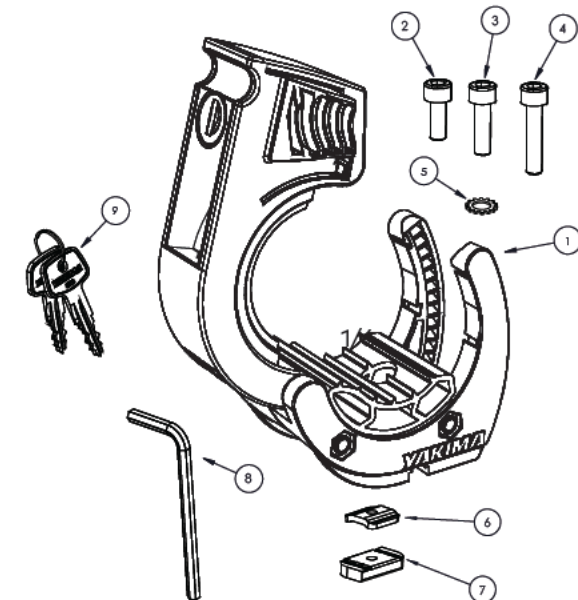

INSTALLATION

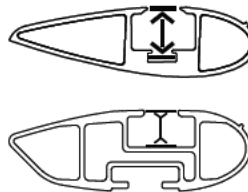
1a  16 mm

INSERT MOUNTING HARDWARE.
Install Deformed Nut on top of bar infill.

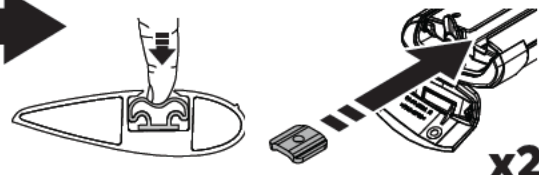

x2

POSITION NUTS IN CHANNEL.

Determine the best spacing for the holders based on the tool you will be carrying. It is recommended to position nuts close to the end of crossbars and ensure they are equally spaced as shown. The allen key can be used to assist nut movement within the channel.

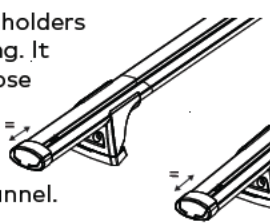

Proceed to step 2.

1b  20 mm

INSERT & ASSEMBLE MOUNTING HARDWARE.

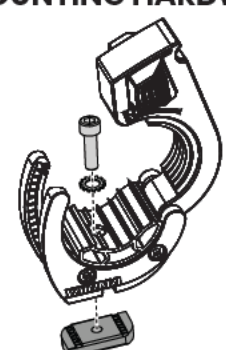

x2

POSITION NUTS IN CHANNEL.

Determine the best spacing for the holders based on the tool you will be carrying. Ensure they are equally spaced.

Proceed to step 4.

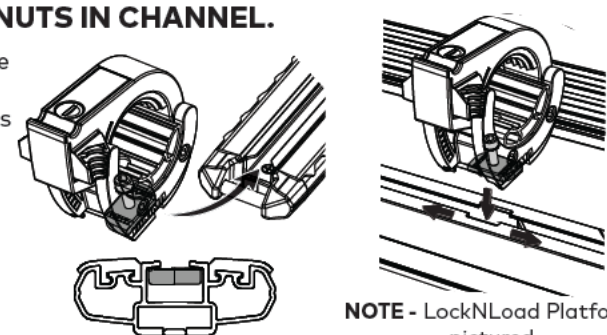

NOTE - TrimHD pictured

NOTE - LockNLoad Platform pictured

x2

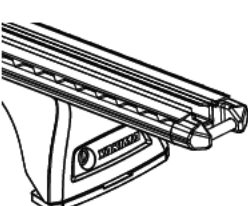
1c  20 mm

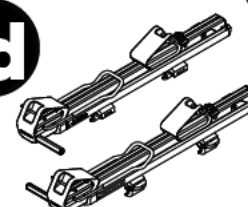
1d **YAKIMA SHOWDOWN**  16 mm

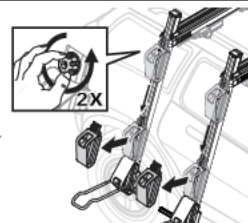

Loosen then slide the inboard saddles all the way down and remove them.

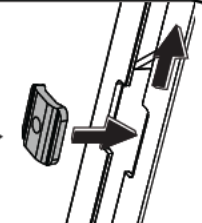
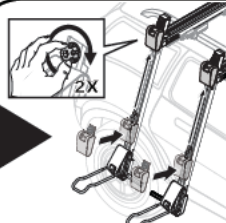

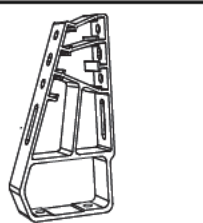

Install the saddles into the slot, raise them up the channel, and tighten them down.

1e  25 mm

INSTALLATION ONTO RECOVERY TRACKS OR ACCESSORY MOUNTING BRACKETS.

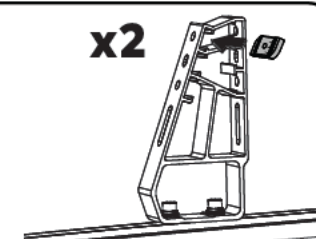
The Slot Nuts can be used to install the Ace'OSpades onto the recovery tracks or accessory mounting brackets as shown and following Steps 2 - 4.



x2

2 INSERT CAP SCREWS INTO SHOVEL HOLDERS (AERO & JETSTREAM BARS).

Assemble 1 x Star Washer onto each Cap Screw.

Insert Cap Screw assemblies through hole in the base of each shovel holder as shown.

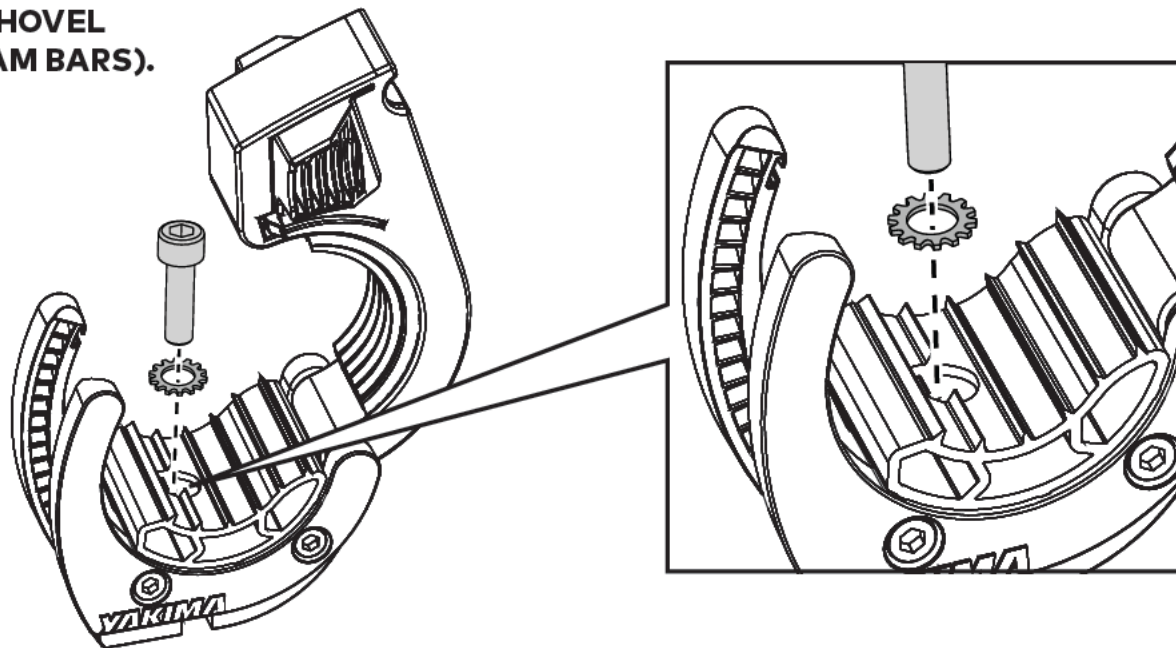

x2

3 POSITION SHOVEL HOLDERS (AERO & JETSTREAM BARS).

Line up Cap Screws in the base of each Shovel Holder into the thread of the nuts in bar channel.

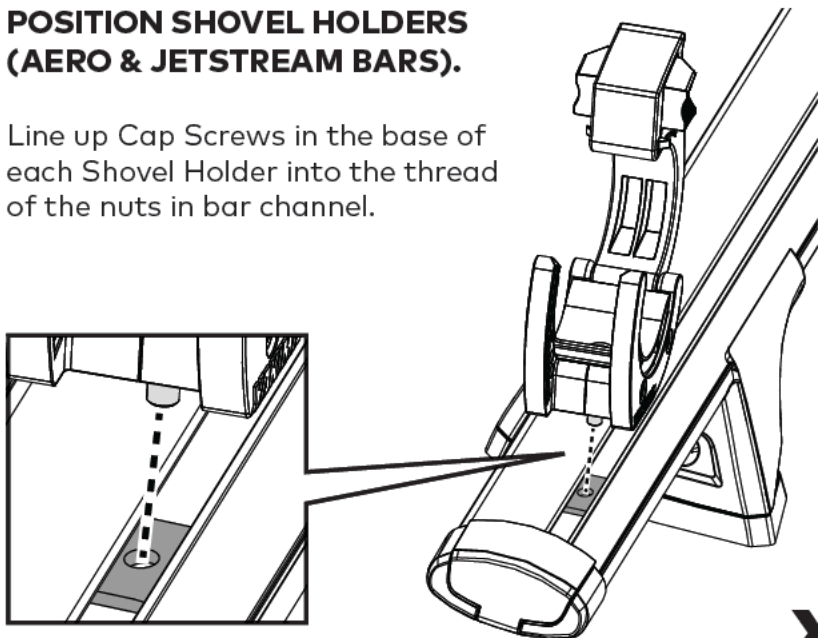

x2

4 SECURE SHOVEL HOLDERS.

Tighten all Cap Screws to 4 Nm with Allen Key provided.

Your AceO'Spades is ready to use.

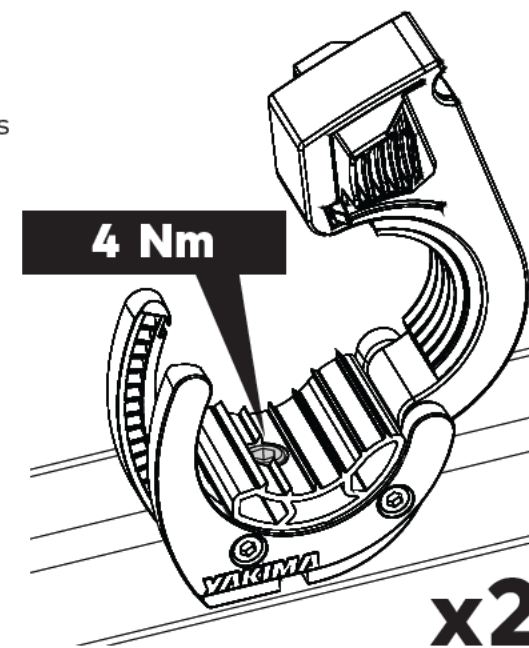

x2

USAGE

5 INSERT TOOL.

Insert tool or paddle down into holders.

Ensure any blades are orientated towards the rear of the vehicle and facing up or away from you. The AceO'Spades can accommodate long handled items with a 30-55 mm shaft diameter including axes, rakes, brooms and oars to a maximum weight of 4 kg.

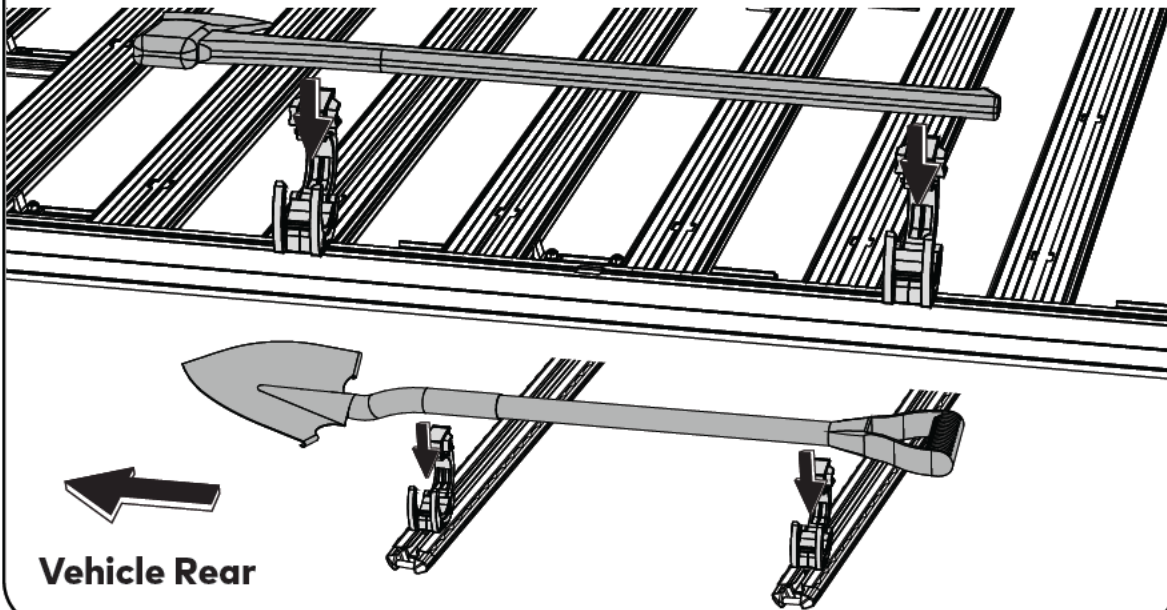

6 SECURE TOOL.

Secure tool within the holder by closing the top claw down over tool handle and pushing it down as far as it can go. The rubber pads should be compressed to ensure a firm hold. If desired, lock shovel holder with keys provided.

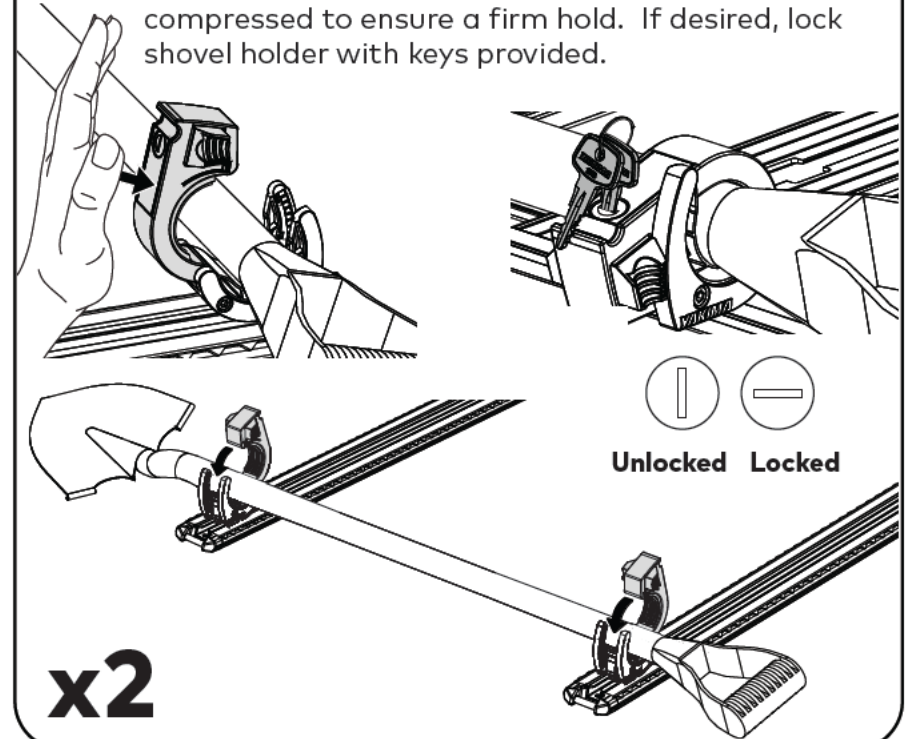

7 TOOL REMOVAL.

To release, unlock the unit using the keys provided (if needed), and then squeeze the side tabs while pulling the top claw upwards.

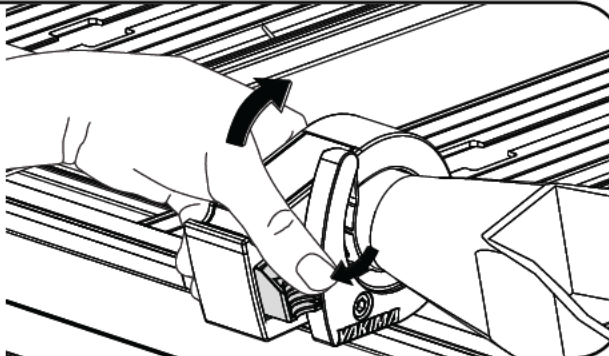

8 WHEN NOT IN USE.

When not carrying an item, close both holders completely to secure rubber pads in place.

If rubber pads are lost, order item SP209 for a replacement kit.

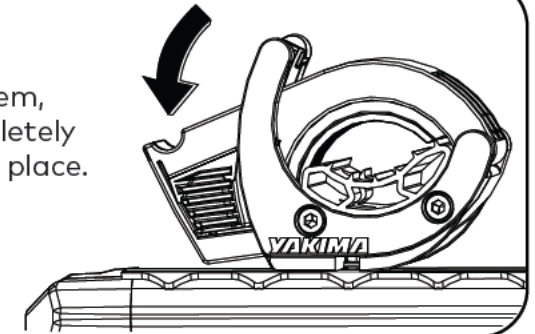

This page intentionally left blank



www.yakima.com.au
www.yakima.co.nz
www.yakima.com
www.yakima.eu

YAKIMA AUSTRALIA PTY LTD

17 Hinkler Court
Brendale, QLD 4500
Australia
1800 143 548

YAKIMA PRODUCTS, INC.

4101 Kruse Way
Lake Oswego, OR
97035-2541
USA
888 925 4621
yakima.com/support

ALL CONTENT SUBJECT TO YAKIMA AUSTRALIA PTY LTD COPYRIGHT © 2024