

FIRST TIME INSTALLATION

- Please read instructions carefully before installation.
- Check the contents of kit. Contact your dealer if any parts appear to be missing or damaged.
- Clean your roof racks/platform prior to fitting the Inline Light Bracket.

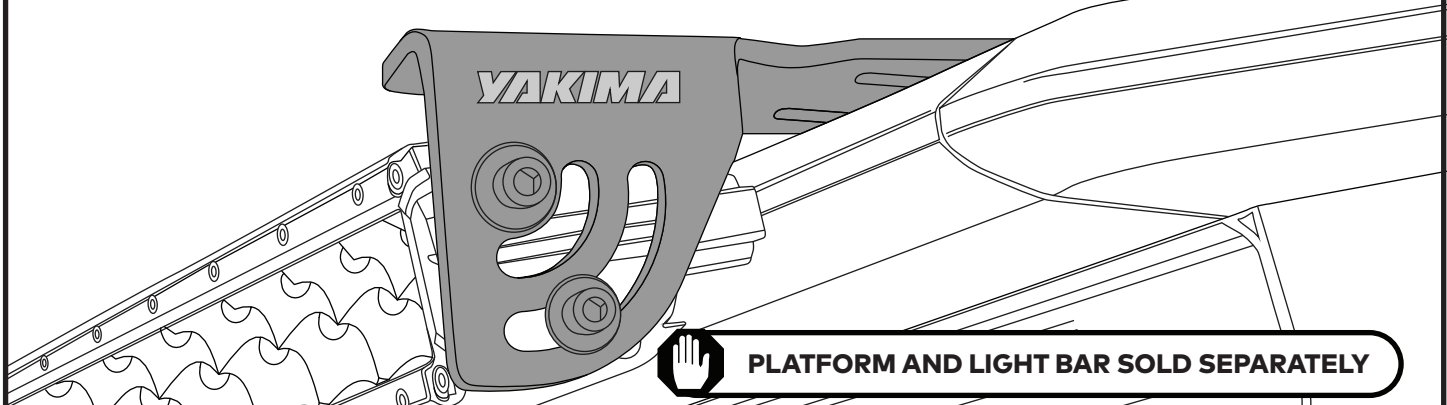

INSTALLATION PROCEDURE

Installation of Light Brackets on TrimHD and HD Bars:
Go to Page 2

Installation of Light Brackets on Aero Deck and LockNLoad Platform:
Go to Page 3

KIT CONTENTS

ITEM	COMPONENT	QTY	ITEM	COMPONENT	QTY
1.	Inline Light Bracket LH	1	5.	M8 Slot Nut	4
2.	Inline Light Bracket RH	1	6.	M8 Washer	6
3.	M8 x 20 mm Button Head Cap Screw	4	7.	M6 Washer	4
4.	M8 x 16 mm Button Head Cap Screw	4	8.	Allen Key	1

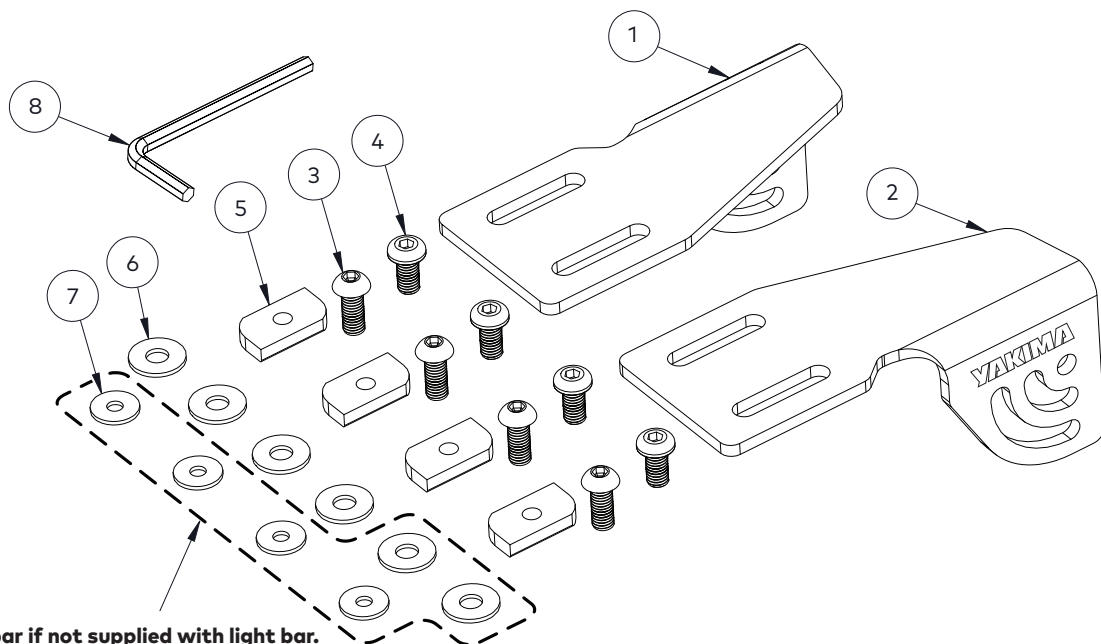

INSTALLATION WITH TRIMHD AND HD BARS

1

ASSEMBLE PARTS.

Attach the **M8 x 20 mm** cap screw, washer and slot nut as shown.

Ensure the slot nut grooves point upwards.

Initially tighten approx 1.5 turns.

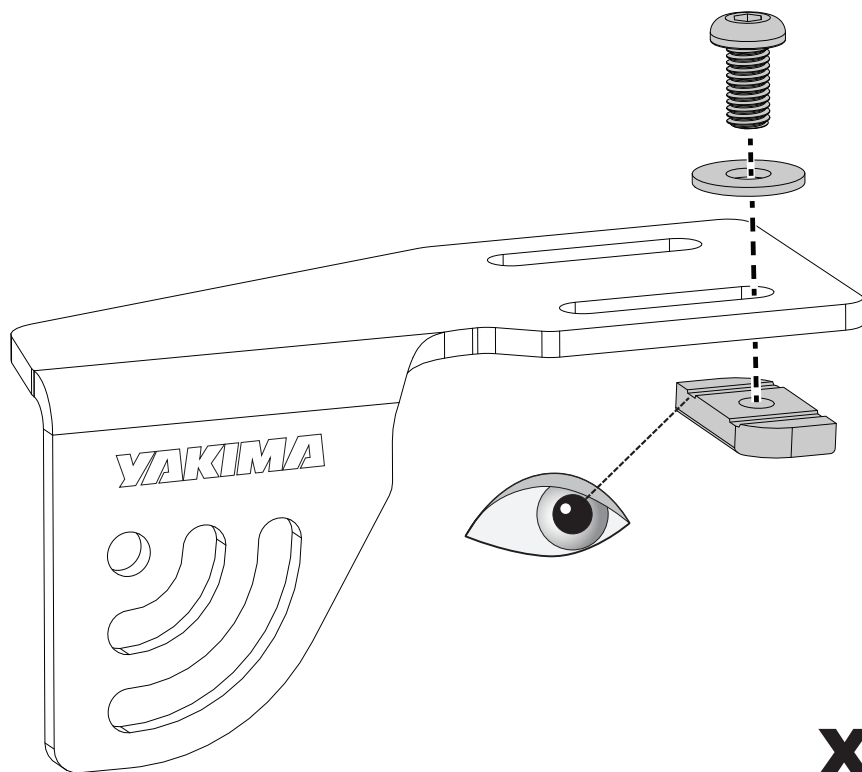

2a

INSTALL BRACKET TO TRIMHD.

For TrimHD installation, insert slot nuts into channel parallel to the slot as shown.

Slide to location.

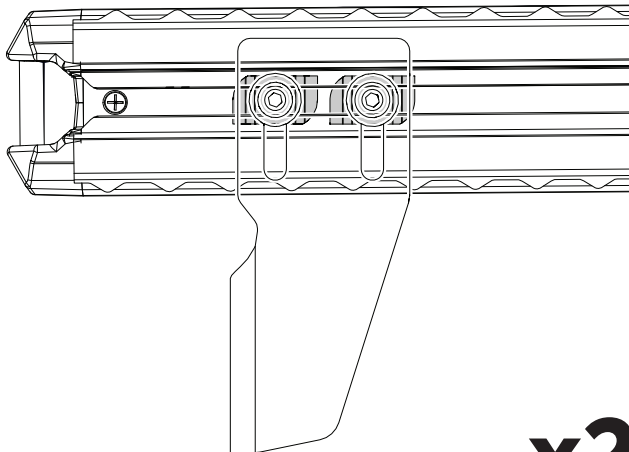

2b

INSTALL BRACKET TO HD BARS.

For HD Bar installation, turn the slot nuts to be parallel within bar channel.

When conveniently located, turn the slot nuts 90 degrees within the channel.

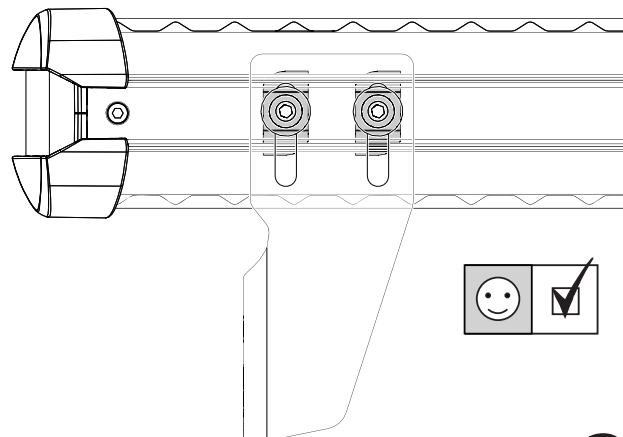

FOR LIGHT BAR MOUNTING INSTRUCTIONS, PROCEED TO PAGE 4

INSTALLATION WITH AERO DECK AND LOCKNLOAD PLATFORM

1 INSERT NUTS.

Insert slot nuts into perimeter channel, parallel to the slot as shown.

Ensure the slot nut grooves point upwards.

Slide to location.

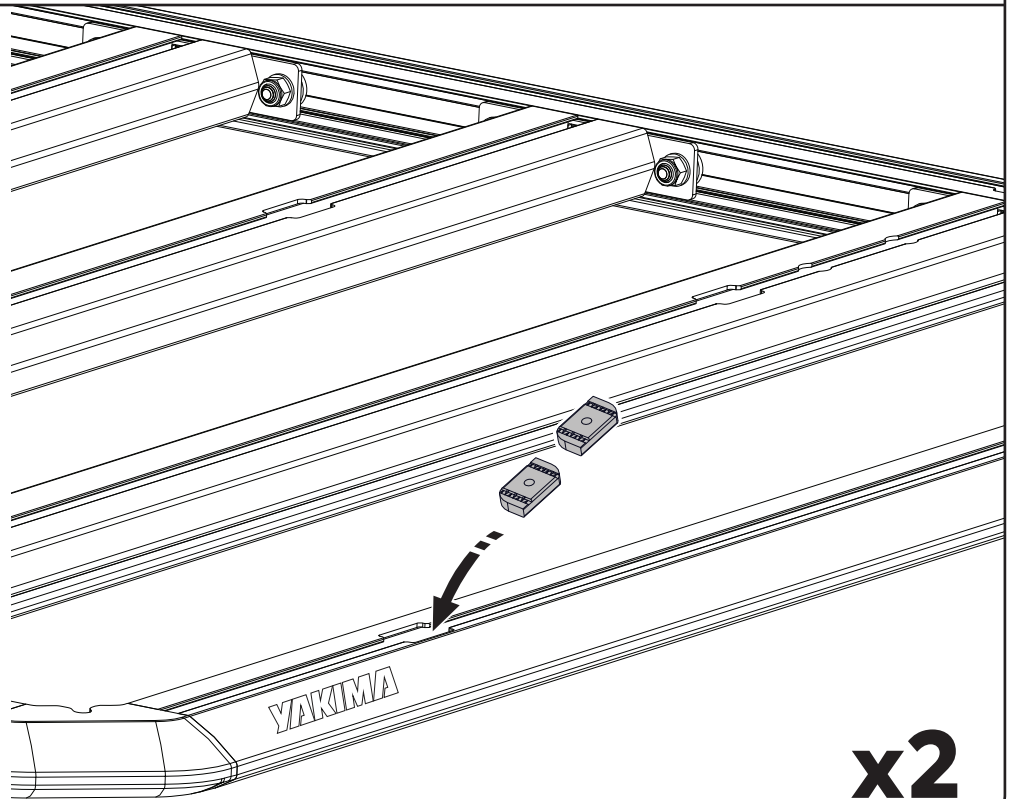

2 ASSEMBLE PARTS.

Assemble the **M8 x 16 mm** cap screw and washer to the bracket as shown.

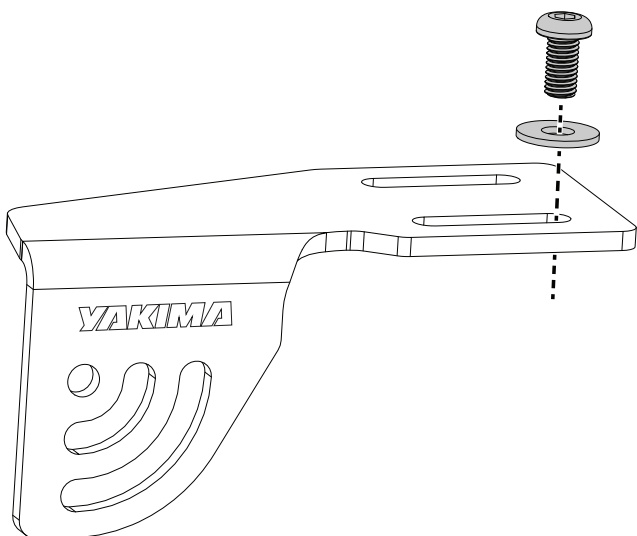

3 INSTALL BRACKET TO PLATFORM.

Attach the bracket assembly to platform by picking up nut threads in channel.

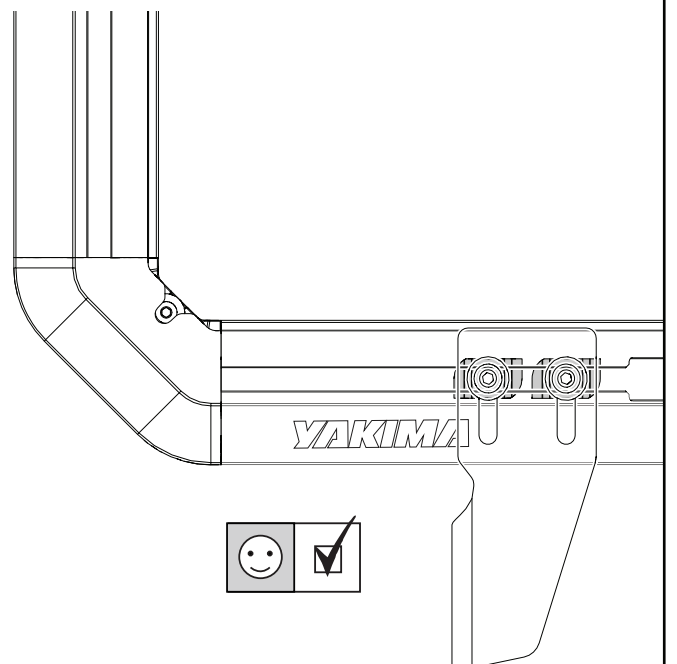

FOR LIGHT BAR MOUNTING INSTRUCTIONS, PROCEED TO PAGE 4

LIGHT BAR MOUNTING INSTRUCTIONS

1 ATTACH LIGHT BAR TO BRACKET.

Attach the light bar to the bracket. Leave loose. Refer to the manufacturers instructions for installation of the light bar.

Maximum weight of the light bar not to exceed 9.0 Kg.

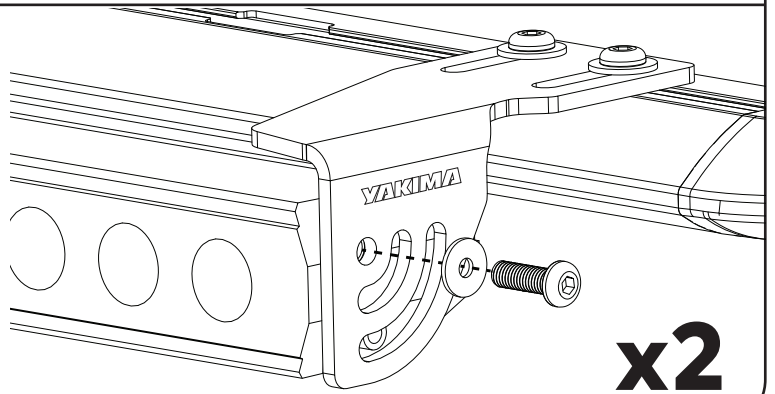

2 SECURE BRACKETS.

Adjust brackets to be equal distance apart from one another, snug down the screw so the Inline Light Bracket is not drooping. Then completely secure the light bar to the brackets using the light bar manufacturers specifications. Lastly tighten the brackets to the Aero Deck or bars. Torque screws to 8 Nm.

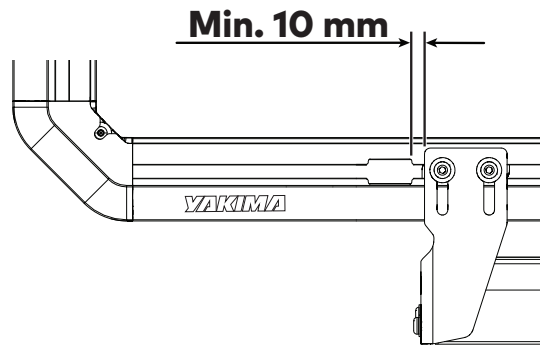
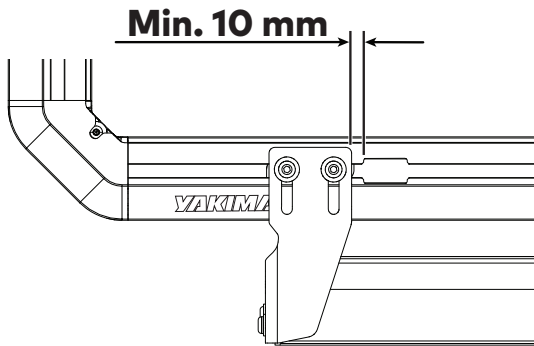
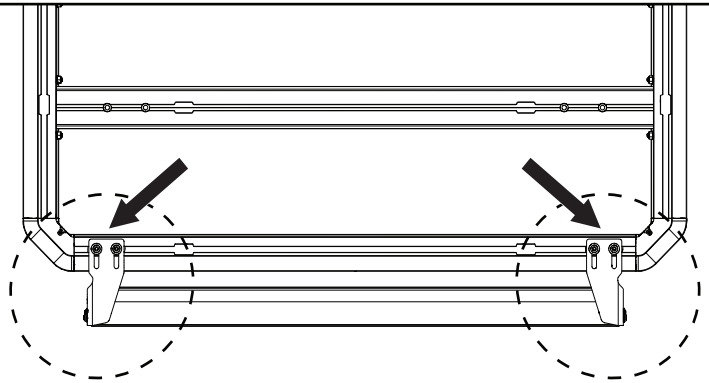

x2

3 LIGHT BAR OPTIONS.

Single row or double row light bars can be attached with the Inline Light Bracket.

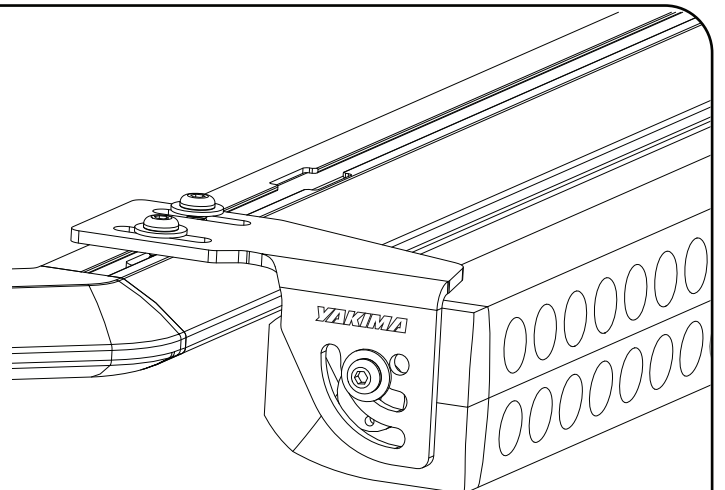
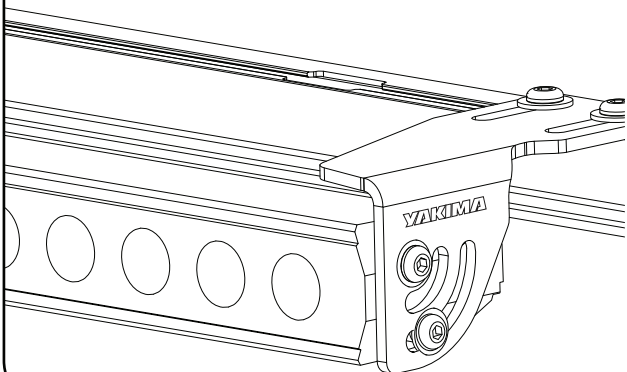

RECOMMENDATIONS

- Check accessory is securely attached whenever you refit it to the vehicle. If the unit feels loose, refer to the fitting instructions and readjust.
- Regularly check all fasteners. This includes all attached accessories and roof racks.
- Refer to local laws regarding the permitted placement and quantity of Light Bars.
- Do not use with curved bars.
- Clean with hot soapy water and sponge as required.

SAFETY

- Ensure all items are securely attached.
- Ensure that all loads are distributed evenly and are fastened securely.
- A loaded roof rack system can alter the performance of your vehicle. Be especially aware of the effects of side winds, changing of direction, and braking performance. Avoid rapid acceleration and deceleration. Drive carefully.
- Make sure all loads are securely fastened with non-elastic straps. Check regularly during longer journeys.
- Never drive into a car wash with the roof rack system or accessories fitted.
- Do not exceed the vehicle manufacturer's roof load rating. Total load equals weight of roof racks + accessories + cargo/equipment.



www.yakima.com.au
www.yakima.co.nz
www.yakima.com
www.yakima.eu

YAKIMA AUSTRALIA PTY LTD

17 Hinkler Court
Brendale, QLD 4500
Australia
1800 143 548

YAKIMA PRODUCTS, INC.

4101 Kruse Way
Lake Oswego, OR
97035-2541
USA
888 925 4621
yakima.com/support