

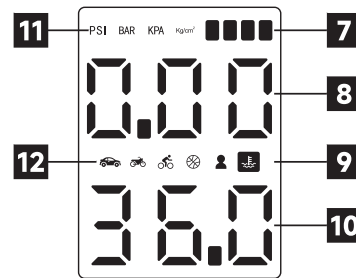

150PSI | 7500mAh Q15 Air Compressor

Product Overview

- ① 3.6" Digital Screen
- ② Start/Stop Inflation Button
- ③ USB-C Input: 5V/2A 9V/2A QC3.0 18W
- ④ USB-A Output: 5V/2.4A
- ⑤ Cooling Vents
- ⑥ Inflation Hose Port
- ⑦ Battery Level (25%, 50%, 75%, 100%)
- ⑧ Real-time Pressure
- ⑨ High Temperature Indicator
- ⑩ Preset Pressure
- ⑪ Unit of Measure
- ⑫ Inflation Mode

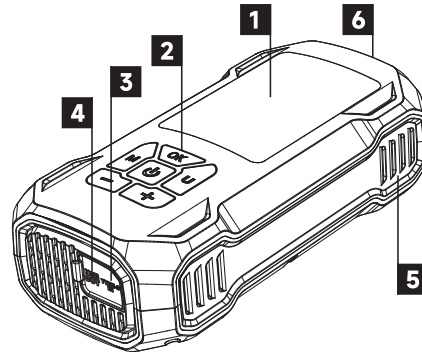

Button Instruction

	Power On/Light Button Press to power on. Push and hold for 3 seconds to activate or turn off light modes. Unit automatically powers off after 45 seconds of non-use.
	Mode Button Press the M button to switch the inflation mode.
	Unit Button Press the U Button to switch the unit of measure.
	Increase Pressure Button Press the + button to increase the pressure value.
	Decrease Pressure Button Press the - button to decrease the pressure value.
	Start/Stop Inflation Button Press the OK button to Start/Stop inflation. Press the OK button for 3 seconds to shut off the air compressor.

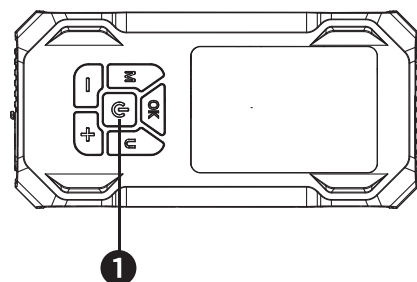

Light Instruction

- Press the power button for 3 seconds to turn the LED flashlight on/off.
- Press the Power button 1 second each time for Flashlight/SOS/Strobe modes.





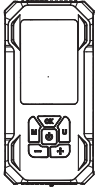
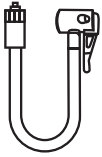
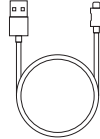
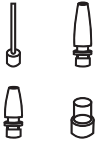

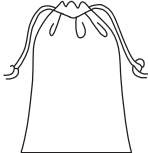



- ① Power On/Light Button

What's In The Box



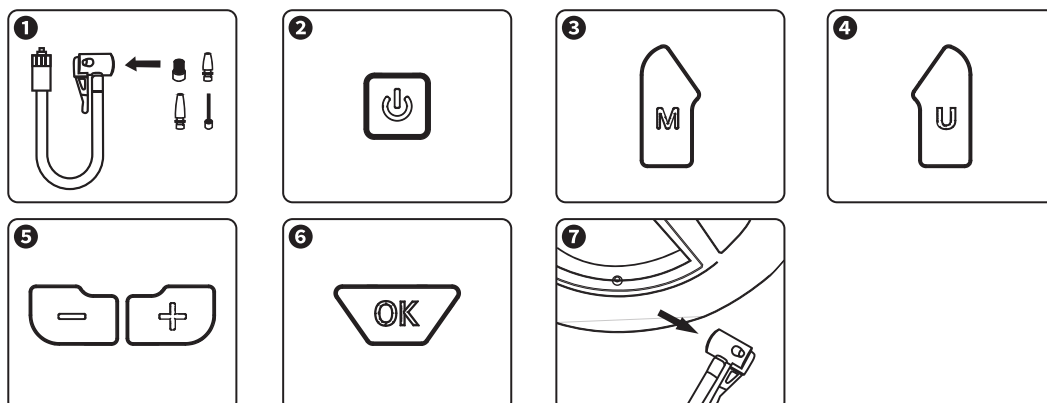

		
Main Unit	Inflation Hose	USB A-C Charging Cable
		
Inflation Adapters	User Manual	Cloth Storage Bag

How To Inflate Tires and Balls

- ① Screw the orange end of the inflation hose  onto the main unit. Select the correct adapter to connect with the inflation hose , press the valve head to secure it, and then insert it into the inflation object. Ensure that both ends are securely fastened to prevent air leakage.
- ② Press  button to activate the unit.
- ③ Press  button to select the inflation object, such as car, motorcycle, bike, ball, or manual adjustment.
- ④ Press  button to choose the unit of measure, such as PSI, BAR, KPA, or Kg/cm².
- ⑤ Press   button to adjust the required air pressure value and long press for rapid adjustment. (Please ensure you know the correct tire pressure value in advance. Most tires generally have a tire pressure range marked on the outer tire. You can also refer to the table below for guidance.)
- ⑥ Press  button to start inflating the tire. When the real-time pressure reaches the set pressure, the air compressor will automatically stop. You can also press the OK button to manually stop the inflation.
- ⑦ Remove the inflation hose once the proper pressure is achieved.



Recommended Inflation Pressure

	Car	Car tire	30~40PSI	2.21~2.76BAR
	Motorcycle	Motorcycle tire	26~40PSI	1.79~2.76BAR
	Bike	12/14/16 inch bike tire	30~50PSI	2.07~3.45BAR
		20/22/24 inch bike tire	40~50PSI	2.76~3.45BAR
		26/27.5/29 mountain bike tire	45~65PSI	3.01~4.88BAR
		700C tube road bike tire	120~145PSI	8.28~9.99BAR
	Ball	Basketball	7~9PSI	0.48~0.62BAR
		Football	8~16PSI	0.55~1.10BAR
		Volleyball	4~5PSI	0.28~0.34BAR
		Rugby football	12~14PSI	0.83~0.97BAR
	Manual adjustment	Manual adjustment	3~150PSI	0.21~10.34BAR

Inflate Balloons, Swimming Rings, And Inflatable Toys

All items that are normally filled by mouth need to be filled in manual mode. Turn off air compressor when desired firmness is reached as you would by mouth.

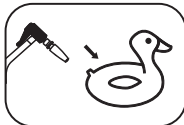

STEP 1: Connect inflation hose to the inflatables with proper nozzle adapter.



STEP 2: Press the  button to start inflating.



STEP 3: Press the  button to stop inflating.

Charge Your Devices

You can charge your phones, tablets, cameras, drones, and more using the “USB OUT” ports.

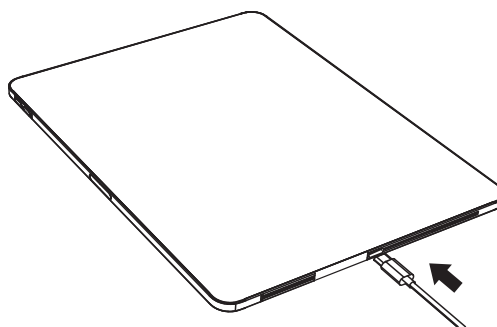
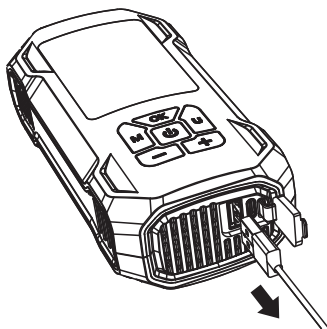

Charge Q15 Air Compressor

Plug the USB-C end of the included charging cable into the "TYPE-C IN" port on the air compressor. Connect the other end to a charger.

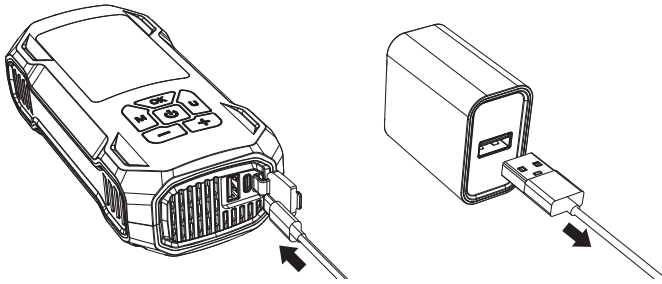

Caution

1. Do not remove the screws to open the unit. The unit does not have any serviceable components inside. The warranty will be void if the unit has been tampered with.
2. Do not discard unit into fire. The lithium battery will cause a fire and possible explosion.
3. Keep out of direct sunlight and extreme hot or cold temperatures.
4. This is not a toy. Keep safely stored away from children. Children should not be present when using the air compressor.
5. Keep unit dry. The unit should not be used near standing water or wet areas such as bathtubs, showers, sinks, swimming pools or basements.
6. It is strictly forbidden to use this product in an environment where flammable gas is present.
7. Make sure the correct unit of measure is chosen i.e. PSI, BAR, KPA, or Kg/cm² to avoid incorrect lower or higher air pressure.
8. Always monitor the pressure closely to avoid over inflation when not using preset pressure mode.
9. Charge unit fully before first time using.

STORAGE: -4°F ~ 158°F (-20°C ~ 70°C)

DISCHARGE: 14°F ~ 122°F (-10°C ~ 50°C)

CHARGE: 32°F ~ 113°F (0°C ~ 45°C)

CAROSS LLC

990 Industrial Rd.

San Carlos, CA 94070

Support@caross.net



How-To Video